

W22 Brake Motor

Three-phase Electric Motor

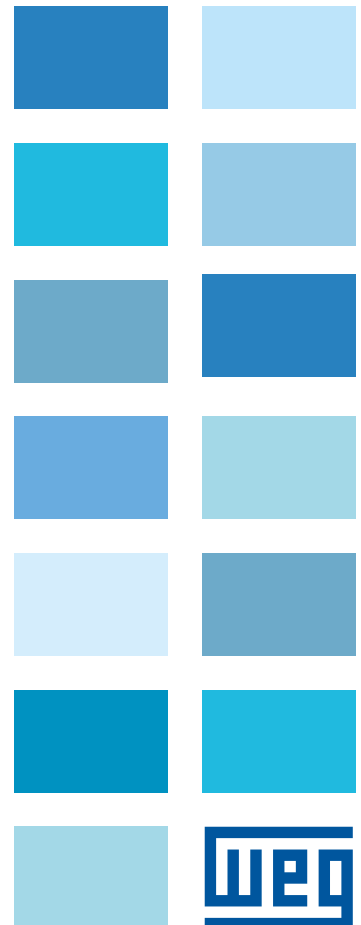
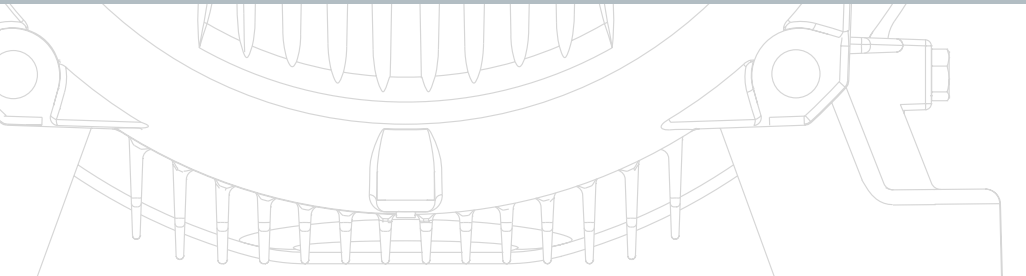
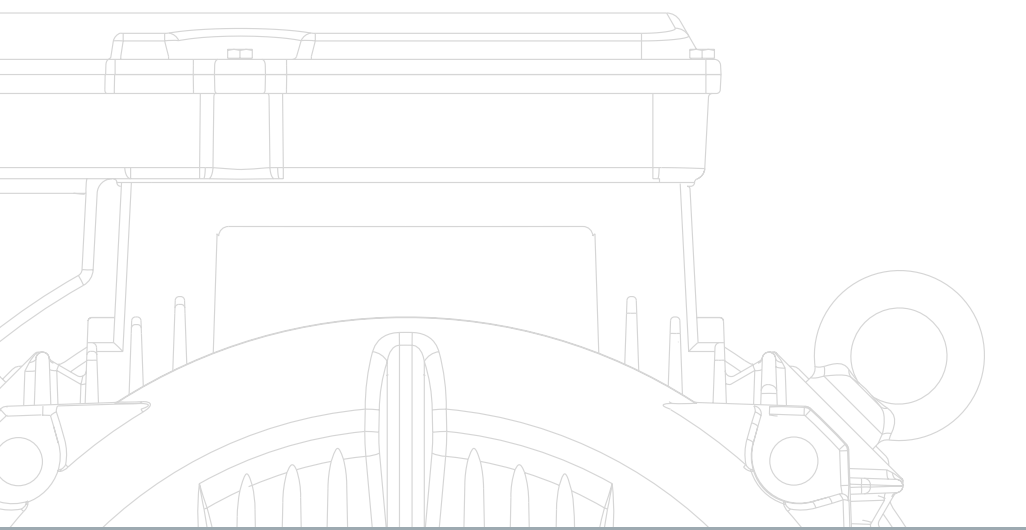

Visual index

Main motor parts

1	Sealing system	8	Fan
2	Endshields	9	Bridge rectifier
3	Bearings	10	Terminal block
4	Shaft	11	Terminal box
5	Rotor	12	Frame
6	Eyebolt	13	Stator
7	Fan cover	14	Shaft key

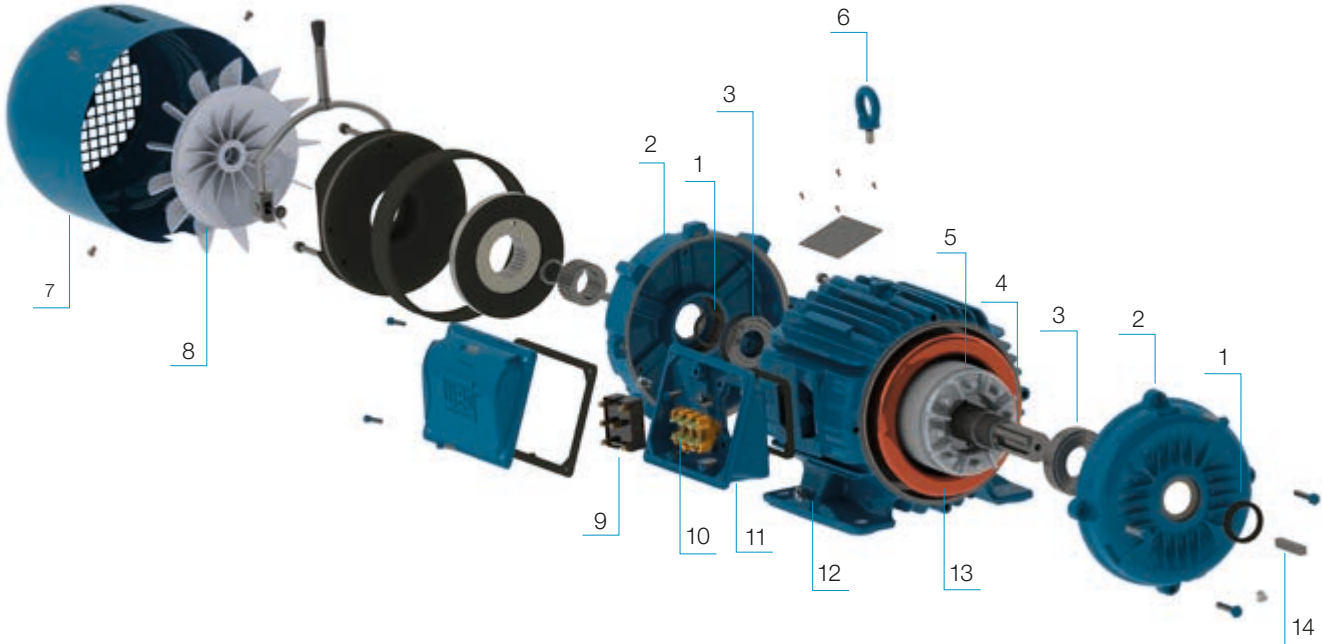

Main brake parts

1	Fastening screw	6	Retaining ring
2	Release lever	7	Hub
3	Brake stator (electromagnet)	8	Key
4	Brake disc	9	Sealing system
5	Brake seal	10	ND-endshield

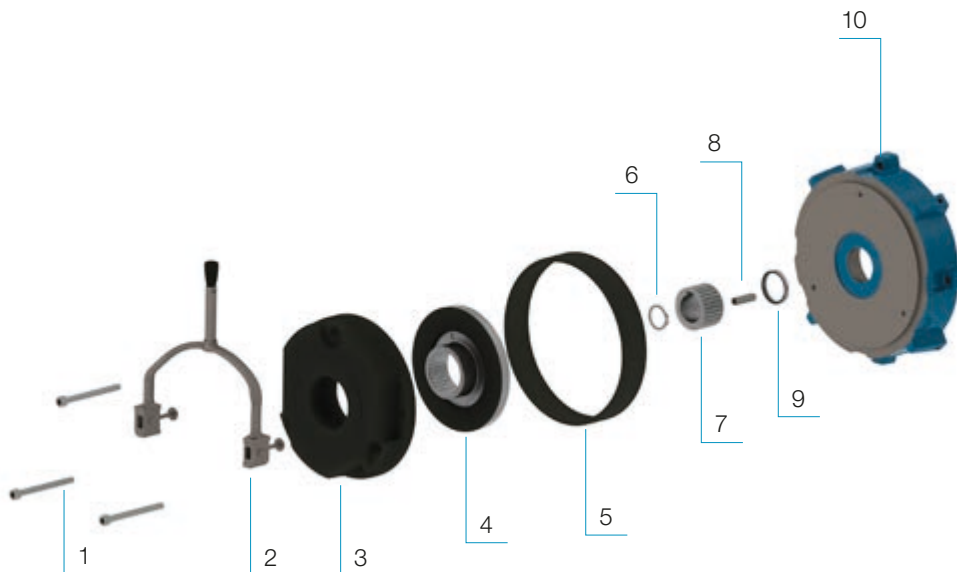

W22 Brake Motor: new platform, new brake, excellent performance!

In order to obtain productivity and high performance, a company must count on reliable equipment, operating in accordance with its purpose. That is the essence of the W22 brake motor: provide the production process with synergy and agility.

Featuring a new braking system, high torque and durability, the W22 brake motor is ideal for equipment that requires fast stops for safety, accurate positioning and time saving.

The new brake motor introduces new characteristics in the braking system and platform, which now counts on the same innovative features that make the W22 line a great success:

- Frame structure that reduces air dispersion and improves the cooling
- Terminal box with greater internal space and easy handling
- Solid feet that simplify the motor alignment and installation
- Frame providing high mechanical strength and low vibration levels

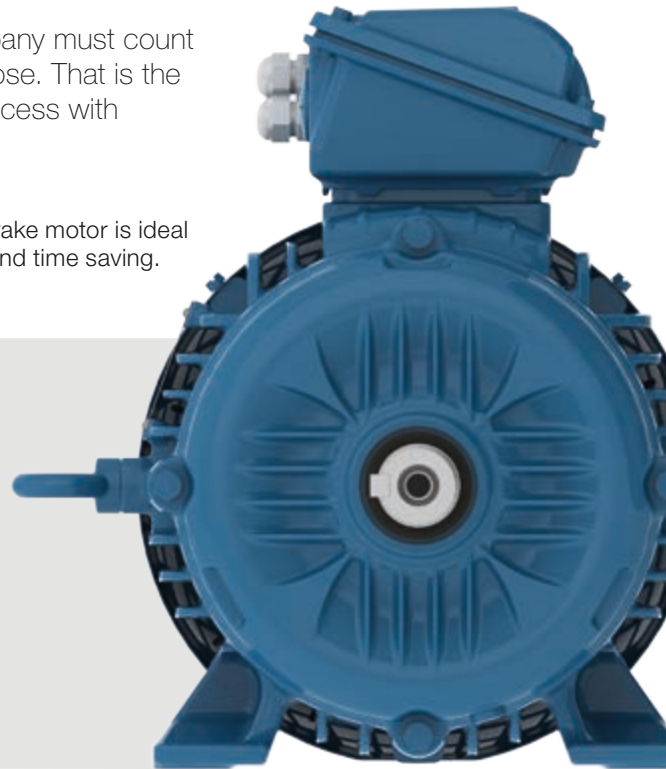

Features

Standard

- Rated output: 0.12 kW to 75 kW
- Number of Poles: 2 to 8
- Frame size: 63 to 250S/M
- Frequency: 50 Hz
- Voltage:
 - 220-240/380-415 V (frames 63 to 100L)
 - 380-415/660 V (frames 112M and 250S/M)
- Brake power supply: 220-240 V
- Normally closed brake
- Design: N
- Insulation class: F (DT 80K)
- Degree of protection:
 - IP55 (frames 63 to 132M/L)
 - IPW55 (frames 160M to 250S/M)
- Mounting: B3T
- Cooling method: TEFC (Totally Enclosed Fan-Cooled) - IC411
- Frame and terminal box material: Cast iron FC-200
- Fan material:
 - Plastic (frames 63 to 132M/L)
 - Aluminum (frames 160M to 250S/M)
- Shaft material: AISI 1040/45
- Ball bearings
- DE bearing seal:
 - V-ring (frames 63 to 200L)
 - WSeal® (frames 225S/M and 250S/M)
- NDE bearing: Lip seal
- Painting plan: 207A (frames 63 to 132M/L) and 203A (from frame 160M up), classified as corrosion category C2, according to ISO 12944:2

Optional

- Mounting: B35, B5, V1, V3, V6, among others.
- Degree of Protection: IP56, IP65, IP66
- Frequency: 60Hz
- DE bearing seal: W3 Seal, taconite seal, INPRO/SEAL®
- Vibration level: Degree B
- Winding thermal protection: thermostat or thermistor
- Space heater
- Cable gland
- Drip cover
- Tropicalized internal painting
- Encoder (from frame 90S up)
- Stainless steel screws
- Cooling method: TEBC – Totally enclosed blower cooled (IC 416)
- Insulation class: “H”
- Able to operate with frequency inverter*
- Manual brake release (up to frame 200L)**
- Microswitch to monitor the air gap or brake opening (from frame 100L up)
- Brake power supply:
 - 380-415 V
 - 440-480 V
- Additional terminal box for frames 112M to 250S/M

*For motors able to operate with frequency inverter, WEG recommends the use of thermal protection on the winding.

**Not available for frames 63 to 80 with terminal box on top.

Optimizations of the braking system

New brake

- The friction element of the new brake provides less wear and more safety
- According to platform of world class brake models (interchangeable)
- Guarantee of fast and accurate brakes
- System with fewer moving parts reduces downtime for maintenance

Manual release lever (optional)

- Motor shaft may remain free in emergency situations or when necessary

Standard torques

- The torques are established by frame so as to provide shorter braking times

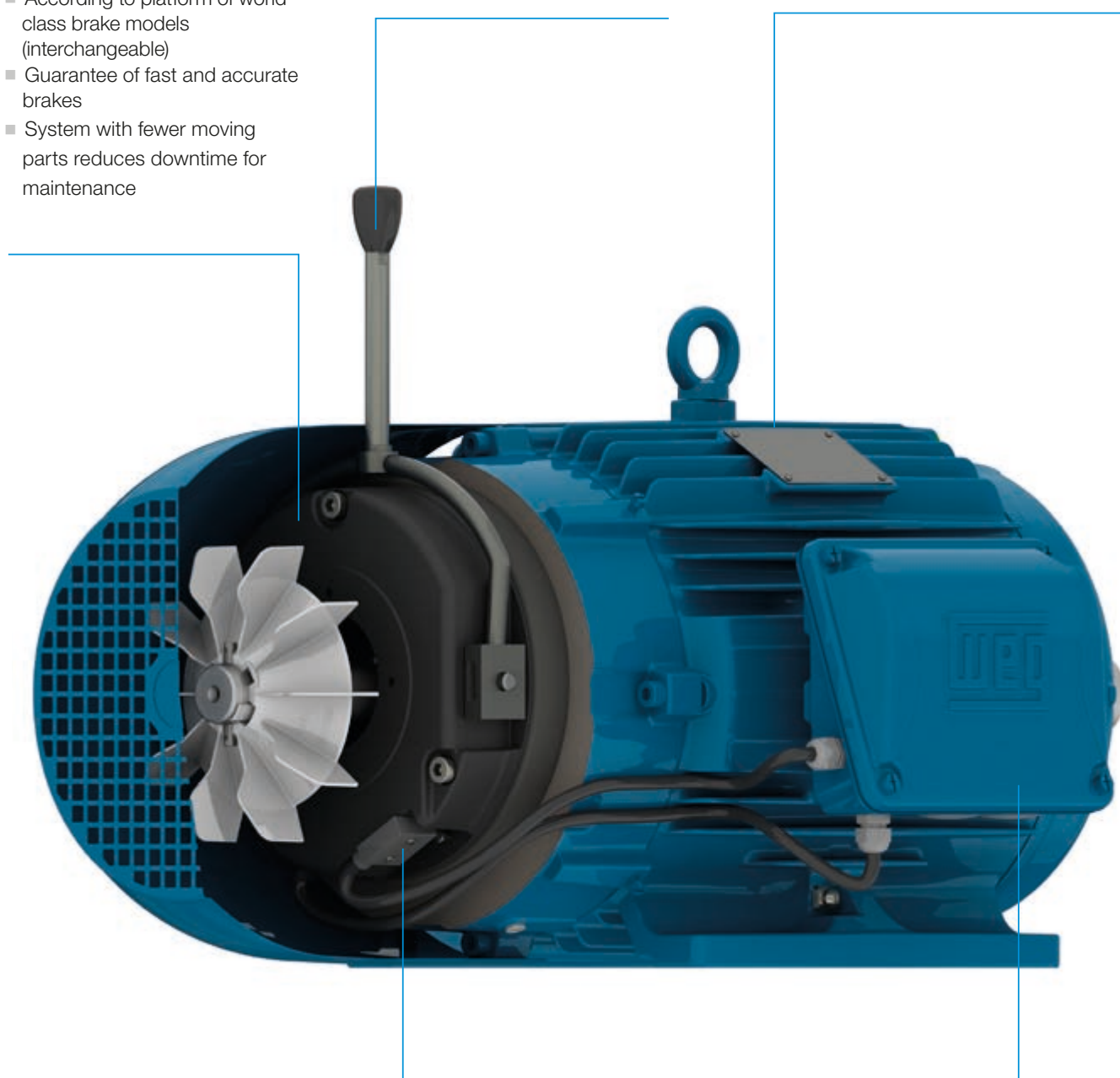

Microswitch (optional)

- Sensor to monitor the opening (I/O) or wear of the brake
- It informs the moment to replace the brake, eliminating the need of manual monitoring

Rectifier

- It can operate with voltage variations of up to 10%
- Robust and compact construction that allows installation in the motor main terminal box

General features

Ideal for applications that require immediate, accurate and safe stops, position control and energy saving. The W22 brake motor is suitable for many different applications, such as load elevators, hoists, shears, machining equipment, looms, packaging machines, conveyors, washing and bottling machines, bending machines, among others.

How does a brake work?

In order to ensure fast and accurate stops, the system of the W22 brake motor works as follows: when the motor is disconnected from the line, the current of the brake coil is also interrupted, which makes the coil stop actuating. Then, the springs push the armature towards the motor, compressing the brake disc between the armature and the ND-endshield, thus braking the motor.

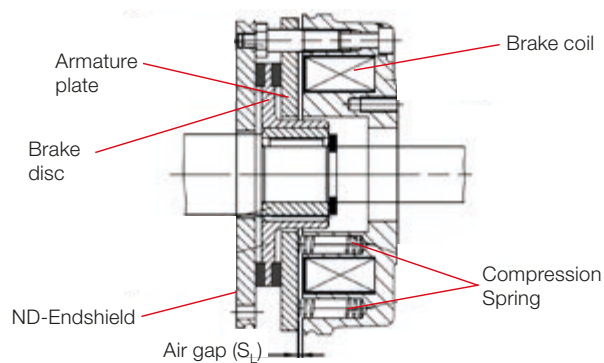

Figure 1 - Scheme of the brake components.

At a new start, the system simultaneously starts the motor and powers up the brake coil. The armature is attracted against the frame of the brake coil, overcoming the pressure of the springs and releasing the brake disc, which moves in the axial direction away from the friction surface. Thus, the braking action ceases and the motor is free to start.

Electromagnetic coil power supply

The electromagnetic coil is powered by direct current (DC) which can be supplied by a DC voltage source or bridge rectifier which converts AC to DC current. The bridge rectifier consists of diodes and varistors that filter undesirable voltage spikes and enable fast current shutdown. The direct current power supply provides higher speed and reliable brake operation.

The alternating current (AC) power supply for the bridge rectifier can be obtained from an independent source, or from the motor terminals, provided the motor is not supplied by frequency inverter. This power supply can be 220/230/240 V, 380/400/415 V, or 440/460/480 V, according to the features of the bridge rectifier/brake coil assembly. The electromagnetic coil can be operated continuously within $\pm 10\%$ of its rated voltage.

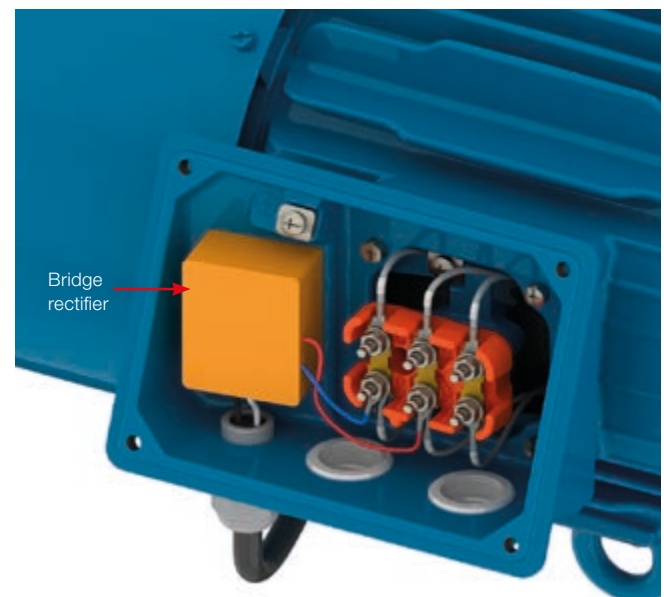

Figure 2 - Detail of the bridge rectifier inside the terminal box.

If the brake coil is supplied by direct current, it must be directly connected to the brake terminals.



Braking system

The W22 brake motor allows two braking system: normal braking or fast braking.

Normal braking

The bridge rectifier of the brake coil can be supplied directly from the motor terminals, without interruption, as shown in Figure 3.

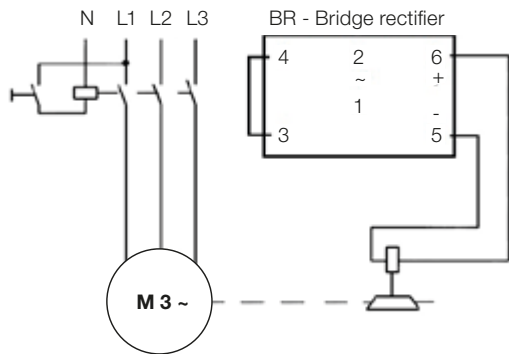

Figure 3 - Connection diagram of the bridge rectifier for normal braking.

Fast braking

For fast braking, the bridge rectifier must be connected as shown in Figure 4.

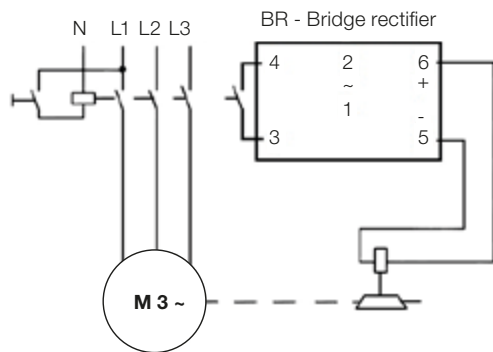

Figure 4 - Connection diagram of the bridge rectifier for fast braking.

Air gap adjustment

In order to ensure proper operation of the brake, it is important to check and adjust the air gap (space between brake armature and frame), according to the values of Table 1.

Frame	Brake size	Air gap (+0.1 / -0.05) [mm]
63	6	0.2
71 e 80	8	
90	10	
100	12	0.3
112	14	
132	16	0.4
160	18	
180	20	0.5
200/225	25	
250	31	

Table 1 - Values to adjust the air gap.

Power and resistance of the brake stator

Frame	Brake size	Brake voltage [V]	Electric power [W]	Resistance [ohm]
63	6	180	20	1,620
		205		2,101
71	8	180	25	1,296
		205		1,681
180		1,296		
205		1,681		
90	10	180	32	1,013
		205	33	1,273
100	12	180	40	810
		205		1,051
112	14	180	53	611.3
		205		792.9
132	16	180	55	589.1
		205	56	750.5
160	18	180	85	387.2
		205		494.4
180	20	180	100	324
		205		420.3
200/225	25	180	110	294.6
		205		382.1
	225/250	31	360	528
920				140.9

Table 2 - Power and resistance of the brake stator.

Optional accessories

In order to ensure even more safety and convenience for the application, the W22 brake motors can be supplied with some special features:

Manual release lever

It allows the motor shaft to be released in emergency cases or power outages. It can be supplied for motors up to frame 200L.

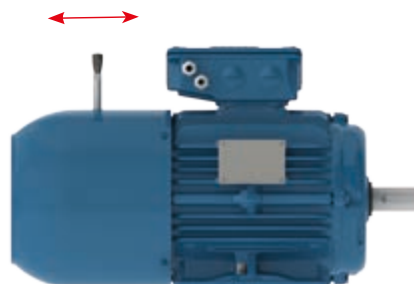

Figure 5 – Detail of the manual release lever.

Note: Under normal operating conditions, the lever cannot be activated.

Microswitch

From frame 100L up, the motors can be supplied with a monitoring sensor of the opening (I/O) or wear of the brake.

- Monitoring of the opening: ensures that the motor will not start if the brake is actuated (it prevents motor starts with the shaft locked);
- Monitoring of the wear: indicates the right moment to adjust or replace the brake lining.

How to choose a W22 brake motor

The W22 brake motor is a motor for quite specific applications that demand high safety and accuracy. Therefore, it is extremely important to take into account some criteria when choosing such equipment.

Basic data to make the best choice:

Determine the motor and the brake: the first step is to define the environment in which the equipment will be used so as to select the motor with the best electromechanical characteristics for the application. The type of brake must also be checked, informing the power supply and the required braking torque.

Define the ambient temperature: taking into account the ambient temperature at which the motor will operate, we can determine the minimum ideal cooling system for the brake operation, according to table 3.

Ambient temperature	Minimum cooling system of the motor
Up to 40°C	No ventilation / W-Easy Maintenance
41°C to 50°C	Self-Ventilated / Air Over
51°C to 60°C	Blower cooled
61°C to 70°C	Blower cooled*

Table 3 - Definition of the cooling system according to the motor ambient temperature.

* For this condition, please contact WEG.

For other cooling system configurations, contact WEG.

Specify the degree of protection: the enclosures of electrical equipment, according to the characteristics and access conditions of the installation environment, must offer a certain degree of protection. Thus, equipment to be installed in a place subject to water jets, for example, must have an enclosure capable of withstanding such jets under certain pressures and angles of incidence without water ingress. Table 4 indicates the minimum cooling system necessary to ensure the degree of protection.

Degree of protection	Minimum cooling system of the motor
IP55	<ul style="list-style-type: none"> ■ No ventilation / Air Over (with fan cover) ■ Self-ventilated ■ With or without release lever
IP56/IP65/IP66	<ul style="list-style-type: none"> ■ Self-ventilated with brake protection cover ■ Without release lever
	<ul style="list-style-type: none"> ■ W-Easy Maintenance ■ With or without release lever

Table 4 - Degrees of protection and minimum cooling systems of the motor.

For other configurations, contact WEG.

Define the braking torque. The W22 brake motor line offers up to two torques per frame:

- Rated torque: standard torque supplied;

- Optional torque: used in load lifting applications, or where, due to the high load torque and/or inertia of the system, it is necessary the use of greater braking torques.

Available braking torques (MK). The braking torque must be equal to or greater than the motor rated torque. Table 5 contains the main characteristics of the brakes, using the speed of 100 rpm as reference.

Frame	Torque at 100 rpm [Nm]		Maximum working speed [rpm]	Maximum dissipated energy Q _e [J]	Brake response time t ₁₂ [s]
	Rated torque	Optional torque			
63	4	-	6,000	3,000	0.015
71	8	-	5,000	7,500	0.017
80		12			
90	16	23	4,000	12,000	0.020
100	32	46	3600	24,000	0.030
112	60	-		30,000	
132	80	125		36,000	
160	150	235		60,000	
180	260	345	3,000	80,000	0.100
200	400	530		120,000	0.120
225	530	800			0.135
250	800	-	2,300	300,000	0.133
	-	1200			

Table 5 - Characteristics of the brake according to the size and torque at 100 rpm.

Maximum braking torque x speed at the moment of the brake: after selecting the motor, note that there is a reduction of the braking torque at speeds above 100 rpm, as shown in Table 6.

Frame	Brake size	Torque at 100 rpm [Nm]	Approximate torque reduction due to the braking at a speed different from 100 rpm [Nm]			
			900 rpm	1200 rpm	1800 rpm	3600 rpm
63	6	4	3.7	3.6	3.4	3.1
71	8	8	7.3	7	6.6	6.1
80		12	10.9	10.5	9.9	9.2
90	10	23	20	19,7	18.6	17.1
100	12	46	40.5	38,7	36.2	33.2
112	14	60	52	50	46.6	42.9
132	16	125	108	103	95.6	87.7
160	18	235	201	189	175	159
180	20	345	291	272	249	228
200	25	530	440	410	371	It cannot be used
225		800	660	620	560	
250	31	1200	940	870	790	

Table 6 - Maximum torque at the braking speed.

Safety factor (k): For regular applications, WEG recommends the use of the safety factor “k” of 1.5 to 2 times the torque value. For special applications, such as lifting, it is recommended a safety factor “k” of 2 to 3 times the rated torque.

Check the brake power supply: The W22 brake motor can be supplied with full, half wave or special bridge rectifiers, as shown in Table 7.

Rated voltage V _{RMS} [Vca]	Brake size	Brake coil voltage [Vcc]	Wave form
110	6 to 25	103	Full
220-240		205	
380-415		180	Half wave
440-480		205	
525-575		250	
220-240	25	205/103	Special = Full/Half wave
400-415	31	360/180	

Tabela 7 - Bridge rectifier types.

Calculations for special applications

Calculation of the required torque for load lifting. For vertical applications, the braking torque must be obtained by means of the required torque calculation (M_{req}), which is given by the following expression:

$$M_{req} = k * \left(\frac{J_L * \Delta n o}{9.55 * \left(t_3 - \frac{t_{12}}{2} \right)} + M_L \right)$$

Where:

M_{req} : required torque [Nm];

“k”: safety factor that must be added due to the uncertainties of the speed at the brake, maximum torque, maximum load inertia, among other variables.

J_L : total inertia on the rotor shaft = load inertia + system inertia + motor inertia [kgm²];

$\Delta n o$: speed [rpm];

t_3 : required braking time [s];

t_{12} : brake response time [s].

Calculation of the required torque for application in translational motion of overhead cranes. For horizontal applications, the braking torque must also be obtained by means of the required torque calculation (M_{req}), which is given by the following expression:

$$M_{req} = \left(\frac{k * J_L * \Delta n o}{9,55 * \left(t_3 - \frac{t_{12}}{2} \right)} \right)$$

Correction of the torque due to the speed at the moment of the brake (M_R): in cases of emergency stops (at working speed) or in motors without frequency inverter, the motor rated speed is considered the braking speed. Thus, the braking torque must be corrected as indicated in Table 8.

Brake size	Torque correction at speed (rpm) [%]							
	750	900	1000	1200	1500	1800	3000	3600
06	93.5	92	91	89.5	87	85	80	78.5
08	92.5	91	89.7	87.7	85	83	78	76.5
10	91.5	89.5	88,2	86	83	81	76	74.7
12	90.5	88.2	87	84.2	81	78.8	74	72.2
14	90	87.5	86	83.5	80	77.7	73	71.5
16	89.5	87	85.5	82.5	79	76.5	72	70.2
18	88	85.7	84	80.7	77	74.5	70	68
20	87	84.5	82.5	79	75	72.2	68	66.2
25	86	83	81	77.5	73	70.1	66	-
31	82	79	77	73	69	65	-	-

Table 8 - Torque correction.

For brakes with frequency inverter, it is necessary to know the speed at which the brake will be performed, and the braking torque must be corrected if necessary.

$$M_R = \frac{M_{req} * 100}{\text{correction} (\%)}$$

Finally, it must be checked if the corrected required torque is equal to or smaller than the torque of the selected brake. If it is bigger, it will be necessary to increase the torque of the brake.

$$M_K \geq M_R$$

Check the cooling of the brake: after selecting the brake, it is necessary to check if the cooling will meet the start duty cycle of the application. The cooling can be obtained through the following equation:

$$Q = \frac{J_L * \Delta n o^2}{182.5} * \frac{M_K}{M_K - M_L}$$

Where:

Q: dissipated heat [J];

M_K : brake torque [Nm];

M_L : load torque [Nm].

With the result found, the value of “Q” must be positioned on the axis of ordinates and the number of starts per hour on the axis of abscissa, and then we should observe if the point is below the curve of the selected brake. If it is below the curve, it indicates that the brake is thermally able to brake the load. Otherwise, the size of the brake must be increased so as to improve the cooling.

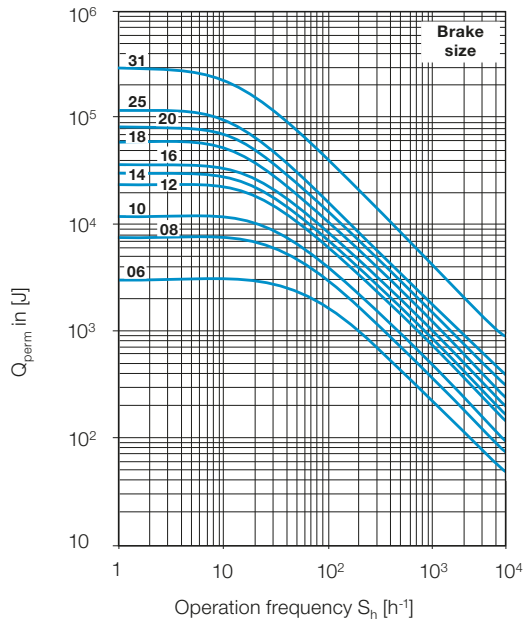

Figure 6 – Cooling curve (Q) according to starts per hour.

Brake power supply. When the brake coil is powered by a bridge rectifier, its input terminals must be supplied with alternate voltage. The relations between the motor voltage, the type of bridge rectifier and the brake coil power supply must be in accordance with table 9.

Motor power supply (connection) [VAC]	Power supply of the brake bridge rectifier [VAC]	Brake type		Supply of the bridge rectifier through the motor electrical connections (IEC-NBR / NEMA)				
		Normal	Fast	Terminal 1 (***)	Terminal 2 (**)			
					3-wire motor	6-wire motor	9-wire motor	12-wire motor
220/230/240 (T)	220/230/240	Figure 3	Figure 4	U1 / T1	W1 / T3	W1 / T3	W1 / T3	W1 / T3
380/400/415 (Y)					NA	W2 / T6	NA	W4 / T12
380/400/415 (T)	W1 / T3				W1 / T3	W1 / T3	W1 / T3	
440/460 (Y)	NA				NA	NA	NA	
440/460 (T)	440/460				W1 / T3	W1 / T3	W1 / T3	W1 / T3
525/550/575 (Y)	NA				NA	NA	NA	
525/550/575 (T)	525/550/575				W1 / T3	W1 / T3	W1 / T3	W1 / T3

Table 9 - Power supply of the bridge rectifier through the motor terminals.

T = Delta connection Y = Star connection NA = Not available

* The bridge rectifier can be directly supplied by the motor cables or independently, at the customer's discretion.

** Terminal markings are only valid for single speed motors.

Note: besides the previous options, the electromagnetic brake with 24-Vdc coil is also available. In this case, only the brake is included (bridge rectifier not supplied) and the brake coil must be powered by an independent source.



Performance Data

W22 Brake Motor - Standard Efficiency - IE1 ^{1) 2)}

Output		Frame	Full load torque (Nm)	Locked rotor current I _L /I _n	Locked rotor torque T _L /T _n	Breakdown torque T _b /T _n	Inertia J (kgm ²)	Allowable locked rotor time (s)		Weight (kg)	Sound dB (A)	400 V								
								Rated speed (rpm)	% of full load						Full load current I _n (A)					
									Efficiency			Power factor								
kW	HP							Hot	Cold			50	75	100	50	75	100			
II pole - 3000 rpm - 50 Hz																				
0.12	0.16	63	0.420	3.8	2.3	2.3	0.0001	27	59	5.3	52.0	2720	45.5	53.5	56.0	0.55	0.68	0.80	0.387	
0.18	0.25	63	0.620	5.0	2.4	2.4	0.0002	10	22	5.7	52.0	2790	52.0	57.0	59.0	0.54	0.67	0.77	0.570	
0.25	0.33	63	0.880	4.3	2.5	2.3	0.0002	25	55	6.1	52.0	2720	52.0	57.0	60.0	0.50	0.65	0.76	0.791	
0.37	0.5	71	1.28	4.9	2.3	2.4	0.0003	16	35	7.0	56.0	2770	62.0	66.5	67.0	0.60	0.75	0.84	0.949	
0.55	0.75	71	1.89	5.0	2.5	2.5	0.0004	7	15	8.0	56.0	2780	64.0	70.0	70.0	0.56	0.71	0.82	1.38	
0.75	1	80	2.60	5.1	2.5	2.6	0.0007	14	31	11.0	59.0	2760	68.5	72.0	72.1	0.62	0.76	0.84	1.79	
1.1	1.5	80	3.75	6.3	2.6	2.6	0.0009	7	15	15.0	59.0	2800	74.0	76.5	76.5	0.64	0.77	0.84	2.47	
1.5	2	90S	5.05	6.3	2.7	2.6	0.0020	7	15	17.5	68.0	2840	77.5	78.5	78.5	0.63	0.76	0.83	3.32	
2.2	3	90L	7.38	6.8	2.6	2.9	0.0026	7	15	19.2	68.0	2850	81.0	81.5	81.5	0.63	0.77	0.85	4.58	
3	4	100L	10.0	6.7	2.3	2.8	0.0059	9	20	27.5	67.0	2870	81.5	82.0	82.0	0.69	0.81	0.87	6.07	
4	5.5	112M	13.3	6.8	2.4	3.0	0.0081	9	20	37.0	64.0	2875	82.0	84.0	85.0	0.71	0.82	0.87	7.81	
5.5	7.5	132S	18.1	6.5	2.4	3.0	0.0180	11	24	51.0	68.0	2910	85.0	86.0	86.0	0.71	0.81	0.87	10.6	
7.5	10	132S	24.7	6.4	2.3	2.6	0.0234	11	24	74.0	68.0	2900	85.5	86.5	86.5	0.72	0.82	0.87	14.4	
9.2	12.5	132M	30.2	7.5	2.7	3.1	0.0234	8	18	74.0	68.0	2910	87.0	87.5	87.5	0.70	0.81	0.86	17.6	
11	15	160M	35.9	6.8	2.0	2.7	0.0409	11	24	116	67.0	2930	87.8	88.6	88.4	0.70	0.81	0.86	20.9	
15	20	160M	48.9	7.2	2.2	2.8	0.0517	9	20	127	67.0	2930	89.5	89.8	89.5	0.71	0.81	0.86	28.1	
18.5	25	160L	60.1	7.8	2.4	3.1	0.0626	7	15	141	67.0	2940	90.3	90.7	90.3	0.70	0.80	0.86	34.4	
22	30	180M	71.6	7.3	2.2	3.1	0.1084	7	15	185	67.0	2935	90.7	91.0	90.8	0.76	0.84	0.88	39.7	
30	40	200L	97.2	6.3	2.1	2.4	0.1526	18	40	261	72.0	2950	91.6	92.0	91.6	0.76	0.84	0.87	54.3	
37	50	200L	120	6.5	2.2	2.4	0.1950	16	35	273	72.0	2950	92.0	92.5	92.0	0.76	0.84	0.87	66.7	
45	60	200L	146	7.0	2.3	2.5	0.2204	13	29	313	72.0	2955	92.3	92.6	92.5	0.77	0.85	0.88	79.8	
High-Output Design																				
0.37	0.5	63	1.29	5.0	2.2	2.2	0.0002	7	15	8.2	52.0	2740	60.0	62.0	64.0	0.58	0.73	0.82	1.02	
0.55	0.75	80	1.91	5.1	2.6	2.6	0.0004	21	46	9.5	59.0	2755	64.5	68.5	69.0	0.60	0.74	0.83	1.39	
0.75	1	71	2.62	5.5	2.8	2.8	0.0005	12	26	10.5	56.0	2740	71.0	72.0	72.1	0.70	0.82	0.89	1.69	
0.75	1	90S	2.52	6.3	2.7	2.7	0.0012	15	33	28.5	68.0	2840	74.2	76.2	76.2	0.63	0.76	0.82	1.73	
1.1	1.5	90S	3.65	6.3	2.7	2.6	0.0015	7	15	17.5	68.0	2880	74.5	76.5	76.5	0.63	0.76	0.83	2.50	
1.5	2	80	5.22	5.5	2.8	2.7	0.0009	15	33	16.5	59.0	2745	76.0	77.0	77.2	0.71	0.82	0.87	3.22	
1.5	2	90L	5.05	6.3	2.7	2.6	0.0020	7	15	17.5	68.0	2840	77.5	78.5	78.5	0.63	0.76	0.83	3.32	
2.2	3	100L	7.35	7.5	2.2	2.7	0.0053	13	29	31.0	67.0	2860	81.0	81.5	81.5	0.73	0.83	0.88	4.33	
2.2	3	90S	7.48	6.8	2.8	2.9	0.0021	9	20	19.2	68.0	2810	81.0	81.5	81.5	0.63	0.77	0.85	4.58	
3	4	112M	9.97	7.2	2.4	2.8	0.0063	20	44	43.0	64.0	2875	83.0	83.5	83.5	0.75	0.84	0.89	5.83	
3	4	90L*	10.2	6.0	3.4	3.0	0.0025	7	15	26.0	64.0	2820	81.0	81.5	81.5	0.57	0.71	0.80	6.64	
4	5.5	100L	13.3	8.4	3.2	3.4	0.0064	8	18	36.0	67.0	2885	83.0	84.0	83.5	0.69	0.81	0.87	7.95	
4	5.5	132S	13.1	6.5	2.3	2.8	0.0187	13	29	70.0	65.0	2910	83.0	84.0	84.0	0.67	0.78	0.85	8.09	
5.5	7.5	112M	18.3	7.7	2.5	3.0	0.0094	10	22	46.0	64.0	2870	85.5	86.0	86.0	0.79	0.86	0.89	10.3	
5.5	7.5	132M	18.1	6.5	2.4	3.0	0.0180	11	24	51.0	68.0	2910	85.0	86.0	86.0	0.71	0.81	0.87	10.6	
7.5	10	112M*	24.9	7.2	3.1	3.2	0.0094	8	18	48.0	64.0	2875	85.5	86.5	86.5	0.64	0.77	0.84	14.9	
7.5	10	132M	24.7	6.4	2.3	2.6	0.0234	11	24	74.0	68.0	2900	85.5	86.5	86.5	0.72	0.82	0.87	14.4	
9.2	12.5	160M	30.1	6.6	1.8	2.5	0.0335	13	29	112	67.0	2925	87.5	88.1	88.0	0.73	0.83	0.87	17.3	
11	15	132M	35.9	8.0	3.0	3.4	0.0270	8	18	83.0	68.0	2925	87.5	89.5	89.5	0.67	0.79	0.85	20.9	
15	20	160L	48.9	7.2	2.2	2.8	0.0517	9	20	127	67.0	2930	89.5	89.8	89.5	0.71	0.81	0.86	28.1	
22	30	160L	71.5	7.8	2.6	3.3	0.0800	7	15	159	67.0	2940	90.5	91.0	91.0	0.73	0.82	0.87	40.1	
22	30	180L	71.6	7.3	2.2	3.1	0.1084	7	15	185	67.0	2935	90.7	91.0	90.8	0.76	0.84	0.88	39.7	
30	40	180L	97.5	8.2	2.2	2.9	0.1301	8	18	223	76.0	2940	91.5	91.8	91.5	0.78	0.86	0.89	52.9	
30	40	200M	97.2	6.3	2.1	2.4	0.1526	18	40	261	72.0	2950	91.6	92.0	91.6	0.76	0.84	0.87	54.3	
37	50	200M	120	6.5	2.2	2.4	0.1950	16	35	273	72.0	2950	92.0	92.5	92.0	0.76	0.84	0.87	66.7	

Notes:

(1) Efficiency values are given according to IEC 60034-2-1. They are calculated according to indirect method, with stray load losses determined by measurement.

(2) With effect from 1st January 2015, IE1 motors placed onto the European Market their design falls outside of the scope of the European Regulation or their final installation will be outside of the EU / EEA.

(*) Temperature rise ΔT 105 K.

Output		380 V								415 V							
		Rated speed (rpm)	% of full load						Full load current In (A)	Rated speed (rpm)	% of full load						Full load current In (A)
			Efficiency			Power factor					Efficiency			Power factor			
kW	HP	50	75	100	50	75	100	50	75	100	50	75	100	50	75	100	
II pole - 3000 rpm - 50 Hz																	
0.12	0.16	2690	48.0	55.0	58.8	0.59	0.74	0.84	0.369	2735	43.0	51.0	53.5	0.52	0.64	0.75	0.416
0.18	0.25	2760	54.0	58.0	59.5	0.59	0.73	0.82	0.560	2810	49.2	55.0	58.0	0.51	0.62	0.73	0.588
0.25	0.33	2685	54.0	59.0	60.0	0.56	0.71	0.81	0.782	2740	50.0	55.5	59.9	0.47	0.60	0.72	0.806
0.37	0.5	2740	64.6	67.5	66.6	0.67	0.81	0.88	0.959	2790	59.1	64.9	66.6	0.55	0.70	0.80	0.966
0.55	0.75	2740	65.4	70.0	70.0	0.61	0.76	0.84	1.42	2810	62.4	69.5	69.5	0.52	0.67	0.79	1.39
0.75	1	2730	70.8	72.7	72.1	0.69	0.82	0.88	1.80	2775	66.2	70.6	72.1	0.56	0.70	0.80	1.81
1.1	1.5	2775	75.3	76.8	76.1	0.70	0.82	0.88	2.50	2815	72.2	75.5	76.4	0.57	0.71	0.80	2.50
1.5	2	2820	78.5	79.1	79.1	0.70	0.81	0.87	3.31	2855	75.5	77.9	78.3	0.57	0.71	0.80	3.33
2.2	3	2830	81.0	81.5	81.5	0.70	0.82	0.88	4.66	2860	80.5	81.3	81.3	0.57	0.72	0.82	4.59
3	4	2855	82.4	83.0	83.0	0.75	0.85	0.89	6.17	2880	80.5	82.4	83.5	0.64	0.77	0.84	5.95
4	5.5	2860	83.0	84.2	84.5	0.77	0.86	0.89	8.08	2885	80.8	83.4	84.8	0.66	0.78	0.85	7.72
5.5	7.5	2895	85.4	86.0	86.0	0.77	0.85	0.89	10.9	2915	84.0	85.5	86.0	0.66	0.78	0.84	10.6
7.5	10	2890	86.3	86.5	86.5	0.78	0.86	0.89	14.8	2910	84.5	86.0	86.5	0.66	0.78	0.84	14.4
9.2	12.5	2900	87.9	88.0	88.0	0.76	0.85	0.89	17.8	2915	85.8	87.5	87.9	0.63	0.76	0.83	17.5
11	15	2920	88.4	88.7	88.1	0.76	0.85	0.88	21.6	2935	87.1	88.3	88.4	0.65	0.77	0.84	20.6
15	20	2945	89.9	89.8	89.1	0.76	0.84	0.88	29.1	2935	89.0	89.7	89.6	0.67	0.78	0.84	27.7
18.5	25	2935	90.8	90.8	90.1	0.75	0.84	0.88	35.5	2945	89.7	90.4	90.3	0.65	0.76	0.84	33.9
22	30	2925	90.9	90.8	90.3	0.80	0.86	0.89	41.6	2940	90.4	91.0	91.0	0.73	0.82	0.87	38.7
30	40	2945	91.8	91.9	91.2	0.80	0.86	0.88	56.8	2955	91.3	92.0	91.8	0.72	0.81	0.86	52.9
37	50	2945	92.2	92.4	91.6	0.80	0.87	0.88	69.7	2950	91.7	92.4	92.1	0.72	0.81	0.85	65.8
45	60	2950	92.5	92.5	92.2	0.81	0.87	0.89	83.3	2960	92.0	92.6	92.6	0.73	0.83	0.87	77.7
High-Output Design																	
0.37	0.5	2690	62.1	62.6	63.0	0.64	0.77	0.86	1.04	2770	57.5	60.9	64.1	0.53	0.68	0.79	1.01
0.55	0.75	2725	66.8	69.3	68.7	0.68	0.80	0.87	1.40	2770	62.2	67.1	68.6	0.55	0.69	0.79	1.41
0.75	1	2710	71.9	71.9	72.1	0.75	0.86	0.91	1.74	2760	70.0	71.7	72.5	0.65	0.79	0.86	1.67
0.75	1	2820	75.2	76.8	76.8	0.70	0.81	0.86	1.73	2855	72.3	75.6	76.0	0.57	0.71	0.79	1.74
1.1	1.5	2860	75.5	77.1	77.1	0.70	0.81	0.87	2.49	2890	72.6	75.9	76.3	0.57	0.71	0.80	2.51
1.5	2	2710	76.8	76.7	77.2	0.77	0.85	0.89	3.32	2765	75.3	76.9	77.7	0.67	0.79	0.85	3.16
1.5	2	2820	78.5	79.1	79.1	0.70	0.81	0.87	3.31	2855	75.5	77.9	78.3	0.57	0.71	0.80	3.33
2.2	3	2840	81.0	81.2	81.2	0.77	0.86	0.89	4.52	2870	80.5	81.5	81.9	0.70	0.81	0.86	4.25
2.2	3	2790	81.0	81.5	81.5	0.70	0.82	0.88	4.66	2820	80.5	81.3	81.3	0.57	0.72	0.82	4.59
3	4	2860	83.5	83.4	82.8	0.79	0.87	0.90	6.12	2885	82.4	83.4	83.7	0.71	0.81	0.87	5.73
3	4	2800	82.1	81.7	81.5	0.63	0.76	0.84	6.66	2835	79.8	81.0	81.6	0.52	0.67	0.77	6.64
4	5.5	2870	83.9	84.3	83.2	0.75	0.85	0.90	8.12	2895	81.9	83.6	83.5	0.64	0.77	0.84	7.93
4	5.5	2900	83.5	84.0	84.8	0.73	0.83	0.87	8.24	2920	81.0	84.0	85.0	0.63	0.75	0.82	7.98
5.5	7.5	2860	86.0	86.5	86.2	0.82	0.88	0.90	10.7	2880	85.0	86.5	86.7	0.76	0.84	0.88	9.92
5.5	7.5	2895	85.4	86.0	86.0	0.77	0.85	0.89	10.9	2915	84.0	85.5	86.0	0.66	0.78	0.84	10.6
7.5	10	2860	86.8	86.9	86.3	0.71	0.82	0.88	15.0	2885	84.3	85.9	86.3	0.57	0.71	0.80	15.1
7.5	10	2890	86.3	86.5	86.5	0.78	0.86	0.89	14.8	2910	84.5	86.0	86.5	0.66	0.78	0.84	14.4
9.2	12.5	2915	87.9	88.0	87.5	0.77	0.86	0.89	17.9	2930	87.0	88.0	88.2	0.69	0.80	0.85	17.1
11	15	2915	88.5	89.5	89.0	0.74	0.84	0.88	21.3	2930	86.4	89.0	89.5	0.60	0.74	0.81	21.1
15	20	2945	89.9	89.8	89.1	0.76	0.84	0.88	29.1	2935	89.0	89.7	89.6	0.67	0.78	0.84	27.7
22	30	2930	90.7	91.0	91.0	0.77	0.84	0.88	41.7	2945	90.2	90.8	90.8	0.70	0.80	0.86	39.2
22	30	2925	90.9	90.8	90.3	0.80	0.86	0.89	41.6	2940	90.4	91.0	91.0	0.73	0.82	0.87	38.7
30	40	2935	91.6	91.6	91.1	0.81	0.88	0.90	55.0	2945	91.3	91.8	91.7	0.75	0.84	0.88	51.4
30	40	2945	91.8	91.9	91.2	0.80	0.86	0.88	56.8	2955	91.3	92.0	91.8	0.72	0.81	0.86	52.9
37	50	2945	92.2	92.4	91.6	0.80	0.87	0.88	69.7	2950	91.7	92.4	92.1	0.72	0.81	0.85	65.8

Performance Data

W22 Brake Motor - Standard Efficiency - IE1 ^{1) 2)}

Output		Frame	Full load torque (Nm)	Locked rotor current I _L /I _n	Locked rotor torque T _L /T _n	Breakdown torque T _b /T _n	Inertia J (kgm ²)	Allowable locked rotor time (s)		Weight (kg)	Sound dB (A)	400 V						Full load current I _n (A)	
								Rated speed (rpm)	% of full load			Power factor							
									Hot			Cold	Efficiency	50	75	100	50		75
IV pole - 1500 rpm - 50 Hz																			
0.12	0.16	63	0.850	3.5	1.8	2.0	0.0003	38	84	6.2	44.0	1350	46.0	53.0	55.0	0.51	0.64	0.75	0.420
0.18	0.25	63	1.26	3.8	1.9	1.9	0.0006	16	35	7.2	44.0	1370	51.0	55.0	57.0	0.52	0.65	0.75	0.610
0.25	0.33	71	1.74	3.7	1.8	1.9	0.0006	28	62	7.0	43.0	1370	53.0	58.0	60.0	0.50	0.62	0.73	0.820
0.37	0.5	71	2.58	3.6	2.0	2.0	0.0007	28	62	8.5	43.0	1370	58.0	62.0	63.0	0.50	0.64	0.73	1.16
0.55	0.75	80	3.71	4.9	2.0	2.4	0.0024	8	18	11.0	44.0	1415	65.0	70.0	71.0	0.57	0.72	0.81	1.38
0.75	1	80	5.03	4.9	2.1	2.3	0.0030	7	15	12.0	44.0	1425	70.0	72.0	72.3	0.58	0.72	0.81	1.85
1.1	1.5	90S	7.35	5.8	1.8	2.4	0.0052	7	15	17.0	49.0	1430	72.5	75.5	75.5	0.60	0.74	0.82	2.57
1.5	2	90L	10.2	5.5	1.9	2.2	0.0066	8	18	25.5	49.0	1410	74.5	77.5	77.5	0.58	0.73	0.82	3.41
2.2	3	100L	14.9	5.6	2.4	2.6	0.0090	9	20	27.0	53.0	1410	79.0	80.0	80.0	0.60	0.74	0.82	4.84
3	4	100L	20.2	6.5	3.1	3.2	0.0082	8	18	34.0	53.0	1420	79.0	81.5	81.5	0.57	0.72	0.81	6.56
4	5.5	112M	26.5	6.2	2.1	2.5	0.0180	9	20	39.0	56.0	1440	82.5	83.5	83.5	0.65	0.77	0.83	8.33
5.5	7.5	132S	35.9	7.5	2.1	2.5	0.0453	7	15	56.0	60.0	1465	84.0	85.5	85.5	0.63	0.77	0.84	11.1
7.5	10	132M	49.1	6.4	2.0	2.5	0.0601	8	18	73.5	60.0	1460	85.5	87.0	87.0	0.63	0.75	0.82	15.2
9.2	12.5	160M	60.2	6.0	2.0	2.4	0.0767	9	20	102	61.0	1460	86.8	87.5	87.4	0.64	0.76	0.82	18.5
11	15	160M	72.0	6.0	2.1	2.5	0.0906	9	20	115	61.0	1460	87.0	88.0	88.0	0.64	0.76	0.82	22.0
15	20	160L	97.8	6.8	2.6	2.8	0.1325	8	18	140	61.0	1465	89.0	89.7	89.3	0.66	0.76	0.83	29.2
18.5	25	180M	121	6.6	2.4	2.8	0.1398	12	26	181	61.0	1465	89.7	90.4	90.2	0.67	0.77	0.84	35.2
22	30	180L	143	6.6	2.4	2.9	0.1653	10	22	193	61.0	1465	90.0	90.8	90.7	0.66	0.77	0.84	41.7
30	40	200L	195	6.6	2.3	2.6	0.2802	13	29	253	65.0	1470	91.3	91.7	91.5	0.68	0.78	0.84	56.3
37	50	225S/M	240	6.7	2.3	2.7	0.3944	10	22	387	66.0	1475	92.0	92.4	92.2	0.71	0.81	0.85	68.1
45	60	225S/M	292	6.9	2.4	2.7	0.4684	10	22	408	66.0	1475	92.2	92.2	92.6	0.72	0.82	0.86	81.6
55	75	250S/M	356	6.5	2.1	2.5	0.7731	12	26	479	66.0	1475	92.9	93.2	93.1	0.73	0.82	0.85	100
75	100	250S/M	484	7.6	2.4	3.0	1.05	8	18	544	66.0	1480	93.1	93.4	93.5	0.73	0.82	0.87	133
High-Output Design																			
0.18	0.25	71	1.27	3.3	1.7	1.9	0.0004	30	66	7.0	43.0	1350	50.0	57.0	58.0	0.50	0.63	0.73	0.614
0.25	0.33	63	1.78	4.1	2.2	2.2	0.0006	23	51	8.2	44.0	1340	55.0	60.0	60.0	0.52	0.66	0.76	0.791
0.37	0.5	80	2.50	5.0	2.0	2.4	0.0015	23	51	10.0	44.0	1415	63.0	66.0	67.0	0.57	0.71	0.81	0.984
0.55	0.75	71	3.98	4.5	2.5	2.3	0.0009	23	51	11.0	43.0	1320	66.0	69.0	69.0	0.50	0.64	0.74	1.55
0.55	0.75	90S	3.71	5.4	2.1	2.4	0.0030	29	64	18.5	49.0	1415	70.0	73.0	73.0	0.56	0.70	0.78	1.39
0.75	1	90S	5.06	5.4	2.0	2.3	0.0036	20	44	19.0	49.0	1415	70.5	73.5	73.5	0.57	0.70	0.79	1.86
1.1	1.5	80	7.43	5.8	2.9	3.0	0.0032	10	22	16.0	44.0	1415	70.5	75.0	75.5	0.56	0.71	0.80	2.63
1.1	1.5	90L	7.35	5.8	1.8	2.4	0.0052	7	15	17.0	49.0	1430	72.5	75.5	75.5	0.60	0.74	0.82	2.57
1.5	2	100L	10.2	5.4	2.1	2.4	0.0052	21	46	28.0	53.0	1405	79.0	79.5	79.0	0.64	0.76	0.82	3.34
1.5	2	90S	10.0	5.5	2.3	2.4	0.0046	8	18	19.5	49.0	1430	74.5	77.5	77.5	0.58	0.73	0.82	3.41
2.2	3	112M	14.6	5.9	1.7	2.5	0.0104	27	59	44.0	56.0	1440	81.0	82.0	82.0	0.59	0.72	0.79	4.90
2.2	3	90L*	14.9	6.2	2.7	2.5	0.0066	8	18	25.5	49.0	1410	79.5	80.0	79.7	0.57	0.71	0.80	5.19
3	4	112M	19.9	5.9	1.7	2.4	0.0123	16	35	45.5	56.0	1440	82.5	83.0	83.0	0.61	0.74	0.81	6.44
4	5.5	100L*	27.4	5.5	2.7	2.7	0.0104	8	18	39.0	53.0	1395	82.0	83.0	83.1	0.62	0.74	0.81	8.58
4	5.5	132S	26.4	6.2	1.5	2.5	0.0283	15	33	66.0	60.0	1450	83.0	84.5	84.5	0.67	0.79	0.85	7.94
5.5	7.5	112M	36.5	6.3	2.2	2.8	0.0180	11	24	50.0	56.0	1440	84.0	85.7	85.7	0.55	0.69	0.77	11.7
5.5	7.5	132M	35.9	7.5	2.1	2.5	0.0453	7	15	56.0	60.0	1465	84.0	85.5	85.5	0.63	0.77	0.84	11.1
7.5	10	132S	49.3	6.7	2.1	2.9	0.0434	8	18	73.5	58.0	1455	85.5	87.0	87.0	0.63	0.77	0.84	14.8
9.2	12.5	132M	60.4	7.5	2.2	2.8	0.0563	6	13	79.0	60.0	1455	86.5	87.7	87.7	0.64	0.78	0.85	17.8
11	15	132M/L*	72.2	7.5	2.4	2.7	0.0676	5	11	92.0	60.0	1455	87.0	88.4	88.0	0.70	0.81	0.88	20.5
11	15	160L	72.0	6.0	2.1	2.5	0.0906	9	20	115	61.0	1460	87.0	88.0	88.0	0.64	0.76	0.82	22.0
15	20	160M	97.8	6.8	2.6	2.8	0.1325	8	18	140	61.0	1465	89.0	89.7	89.3	0.66	0.76	0.83	29.2
18.5	25	160L	121	6.6	2.4	2.9	0.1537	7	15	154	61.0	1465	89.5	90.2	90.0	0.64	0.76	0.82	36.2
18.5	25	180L	121	6.6	2.4	2.8	0.1398	12	26	181	61.0	1465	89.7	90.4	90.2	0.67	0.77	0.84	35.2
22	30	180M	143	6.6	2.4	2.9	0.1653	10	22	193	61.0	1465	90.0	90.8	90.7	0.66	0.77	0.84	41.7
30	40	180L	196	6.7	2.9	2.9	0.2075	10	22	219	61.0	1460	90.5	91.2	91.0	0.63	0.74	0.82	58.0
30	40	200M	195	6.6	2.3	2.6	0.2802	13	29	253	65.0	1470	91.3	91.7	91.5	0.68	0.78	0.84	56.3
37	50	200L	241	6.6	2.3	2.5	0.3342	12	26	266	65.0	1470	92.0	92.4	92.0	0.71	0.81	0.85	68.3
45	60	200L*	292	6.6	2.3	2.5	0.3735	6	13	255	65.0	1475	92.3	92.7	92.5	0.65	0.76	0.82	85.6
55	75	225S/M	356	7.0	2.4	2.7	0.6367	9	20	439	66.0	1475	92.8	93.1	93.1	0.72	0.82	0.82	104

Notes:

(1) Efficiency values are given according to IEC 60034-2-1. They are calculated according to indirect method, with stray load losses determined by measurement.

(2) With effect from 1st January 2015, IE1 motors placed onto the European Market their design falls outside of the scope of the European Regulation or their final installation will be outside of the EU / EEA.

(*) Temperature rise ΔT 105 K.

Output		380 V								415 V							
		Rated speed (rpm)	% of full load						Full load current In (A)	Rated speed (rpm)	% of full load						Full load current In (A)
			Efficiency			Power factor					Efficiency			Power factor			
kW	HP	50	75	100	50	75	100	50	75	100	50	75	100	50	75	100	

IV pole - 1500 rpm - 50 Hz

0.12	0.16	1330	49.6	55.0	55.1	0.56	0.69	0.79	0.419	1360	42.7	50.9	54.0	0.48	0.60	0.71	0.435
0.18	0.25	1350	51.0	55.0	57.0	0.57	0.69	0.80	0.600	1380	48.0	53.0	55.0	0.48	0.59	0.69	0.660
0.25	0.33	1340	57.3	58.9	58.9	0.55	0.68	0.78	0.830	1385	48.9	55.3	59.4	0.47	0.58	0.69	0.840
0.37	0.5	1345	61.5	63.5	62.6	0.55	0.70	0.78	1.15	1385	54.3	59.8	62.5	0.46	0.59	0.69	1.19
0.55	0.75	1400	68.0	71.3	70.9	0.63	0.78	0.85	1.39	1420	62.0	68.4	70.4	0.53	0.68	0.77	1.41
0.75	1	1410	72.2	72.5	72.1	0.64	0.76	0.84	1.88	1435	68.0	71.0	72.4	0.54	0.67	0.78	1.85
1.1	1.5	1415	73.0	75.5	75.5	0.66	0.79	0.85	2.60	1435	70.5	74.5	75.5	0.56	0.70	0.80	2.54
1.5	2	1400	74.5	77.5	77.5	0.65	0.78	0.86	3.42	1415	72.5	77.5	77.5	0.52	0.67	0.77	3.50
2.2	3	1400	79.0	80.5	79.7	0.67	0.79	0.85	4.98	1420	77.5	79.5	80.0	0.55	0.68	0.78	4.90
3	4	1410	80.0	81.5	81.5	0.64	0.77	0.84	6.66	1430	77.0	81.5	81.5	0.52	0.67	0.78	6.57
4	5.5	1430	82.9	83.1	83.1	0.71	0.81	0.86	8.50	1445	81.0	83.0	83.5	0.59	0.72	0.80	8.33
5.5	7.5	1460	85.0	85.5	85.5	0.70	0.81	0.86	11.4	1470	83.2	85.0	85.5	0.58	0.72	0.81	11.0
7.5	10	1455	86.5	86.8	86.8	0.71	0.80	0.85	15.5	1460	83.7	86.2	86.7	0.57	0.70	0.78	15.4
9.2	12.5	1455	87.5	87.6	87.0	0.69	0.79	0.84	19.1	1465	86.1	87.2	87.5	0.60	0.73	0.80	18.3
11	15	1455	87.8	88.2	87.6	0.69	0.80	0.84	22.7	1465	86.1	87.6	88.0	0.59	0.72	0.79	22.0
15	20	1460	89.5	89.7	88.9	0.71	0.79	0.85	30.2	1470	88.4	89.5	89.4	0.62	0.73	0.81	28.8
18.5	25	1460	90.5	90.6	90.0	0.73	0.81	0.87	35.9	1470	89.0	90.1	90.2	0.62	0.73	0.81	35.2
22	30	1460	90.8	91.0	90.5	0.72	0.81	0.87	42.5	1470	89.3	90.5	90.6	0.61	0.73	0.81	41.7
30	40	1465	91.7	91.7	91.2	0.73	0.81	0.86	58.1	1470	90.8	91.5	91.6	0.63	0.75	0.82	55.6
37	50	1470	92.3	92.4	91.9	0.76	0.84	0.86	71.1	1475	91.6	92.3	92.2	0.68	0.78	0.83	67.3
45	60	1470	92.5	92.2	92.3	0.76	0.85	0.87	85.1	1475	91.9	92.1	92.6	0.68	0.79	0.84	80.5
55	75	1470	93.1	93.1	92.7	0.77	0.84	0.86	105	1475	92.6	93.1	93.1	0.70	0.80	0.84	97.8
75	100	1475	93.4	93.4	93.2	0.78	0.85	0.89	137	1480	93.6	93.2	93.5	0.69	0.79	0.85	131

High-Output Design

0.18	0.25	1325	52.9	58.6	57.6	0.54	0.68	0.78	0.609	1365	47.2	55.3	57.5	0.48	0.60	0.70	0.622
0.25	0.33	1320	57.5	61.0	59.6	0.57	0.71	0.80	0.797	1350	52.3	58.4	59.8	0.48	0.62	0.73	0.797
0.37	0.5	1405	65.4	67.0	66.7	0.62	0.76	0.84	1.00	1425	60.6	64.7	66.6	0.53	0.67	0.77	1.00
0.55	0.75	1295	68.7	70.2	68.3	0.55	0.69	0.78	1.57	1330	62.9	67.6	68.7	0.45	0.59	0.70	1.59
0.55	0.75	1405	71.6	73.4	72.3	0.61	0.74	0.81	1.43	1420	68.6	72.3	73.1	0.52	0.66	0.75	1.40
0.75	1	1405	72.0	73.9	72.8	0.62	0.75	0.82	1.91	1420	68.9	72.8	73.7	0.52	0.66	0.76	1.86
1.1	1.5	1405	73.3	76.4	75.7	0.63	0.77	0.85	2.60	1420	67.3	73.1	75.1	0.51	0.65	0.76	2.68
1.1	1.5	1415	73.0	75.5	75.5	0.66	0.79	0.85	2.60	1435	70.5	74.5	75.5	0.56	0.70	0.80	2.54
1.5	2	1390	79.6	79.1	77.7	0.69	0.79	0.84	3.49	1415	78.1	79.4	79.6	0.60	0.73	0.80	3.28
1.5	2	1425	74.5	77.5	77.5	0.65	0.78	0.86	3.42	1435	72.5	77.5	77.5	0.52	0.67	0.77	3.50
2.2	3	1435	82.2	82.3	81.5	0.65	0.76	0.82	5.00	1445	79.9	81.5	82.0	0.55	0.68	0.76	4.91
2.2	3	1390	80.6	80.5	79.7	0.65	0.75	0.83	5.05	1420	77.4	79.5	79.7	0.53	0.66	0.76	5.05
3	4	1435	83.8	83.3	82.5	0.67	0.78	0.84	6.58	1445	81.1	82.5	83.1	0.56	0.70	0.78	6.44
4	5.5	1380	82.8	82.7	81.9	0.67	0.78	0.83	8.94	1405	81.1	82.8	83.7	0.57	0.71	0.79	8.42
4	5.5	1445	84.1	84.7	83.9	0.73	0.83	0.87	8.23	1455	81.9	84.1	84.5	0.62	0.75	0.82	7.93
5.5	7.5	1435	85.5	86.2	85.4	0.64	0.75	0.80	11.9	1445	82.4	84.9	85.4	0.50	0.64	0.73	11.9
5.5	7.5	1460	85.0	85.5	85.5	0.70	0.81	0.86	11.4	1470	83.2	85.0	85.5	0.58	0.72	0.81	11.0
7.5	10	1450	86.5	86.8	86.8	0.71	0.82	0.87	15.1	1455	83.7	86.2	86.7	0.57	0.72	0.80	15.0
9.2	12.5	1450	87.3	87.8	87.4	0.70	0.82	0.87	18.4	1455	85.3	87.1	87.5	0.59	0.73	0.82	17.8
11	15	1450	87.5	88.4	88.0	0.75	0.84	0.89	21.4	1460	86.5	88.4	88.4	0.67	0.79	0.86	20.1
11	15	1455	87.8	88.2	87.6	0.69	0.80	0.84	22.7	1465	86.1	87.6	88.0	0.59	0.72	0.79	22.0
15	20	1460	89.5	89.7	88.9	0.71	0.79	0.85	30.2	1470	88.4	89.5	89.4	0.62	0.73	0.81	28.8
18.5	25	1460	90.1	90.3	89.7	0.69	0.79	0.84	37.3	1470	88.9	90.0	90.1	0.60	0.73	0.80	35.7
18.5	25	1460	90.5	90.6	90.0	0.73	0.81	0.87	35.9	1470	89.0	90.1	90.2	0.62	0.73	0.81	35.2
22	30	1460	90.8	91.0	90.5	0.72	0.81	0.87	42.5	1470	89.3	90.5	90.6	0.61	0.73	0.81	41.7
30	40	1455	91.3	91.4	90.8	0.69	0.78	0.85	59.1	1465	89.8	90.9	91.0	0.59	0.71	0.79	58.1
30	40	1465	91.7	91.7	91.2	0.73	0.81	0.86	58.1	1470	90.8	91.5	91.6	0.63	0.75	0.82	55.6
37	50	1465	92.3	92.4	91.7	0.76	0.84	0.87	70.5	1470	91.5	92.2	92.1	0.66	0.78	0.83	67.3
45	60	1470	93.1	93.0	92.5	0.72	0.81	0.86	85.9	1475	91.3	92.2	92.3	0.58	0.71	0.78	87.0
55	75	1470	93.0	93.0	92.7	0.76	0.84	0.83	109	1475	92.5	93.1	93.3	0.69	0.80	0.81	101

Performance Data

W22 Brake Motor - Standard Efficiency - IE1 ^{1) 2)}

Output		Frame	Full load torque (Nm)	Locked rotor current I _L /I _n	Locked rotor torque T _L /T _n	Breakdown torque T _b /T _n	Inertia J (kgm ²)	Allowable locked rotor time (s)		Weight (kg)	Sound dB (A)	Rated speed (rpm)	400 V						Full load current I _n (A)
								Hot	Cold				% of full load			Power factor			
													Efficiency			Power factor			
kW	HP											50	75	100	50	75	100		
VI pole - 1000 rpm - 50 Hz																			
0.12	0.16	63	1.34	2.6	1.7	1.6	0.0007	46	101	7.7	43.0	855	43.0	47.0	48.0	0.44	0.55	0.67	0.540
0.18	0.25	71	1.91	3.1	2.2	2.2	0.0009	30	66	10.5	43.0	900	46.0	53.0	55.0	0.38	0.49	0.58	0.814
0.25	0.33	71	2.67	3.1	2.2	2.2	0.0008	30	66	13.0	43.0	895	48.0	55.0	57.0	0.38	0.48	0.58	1.09
0.37	0.5	80	3.91	3.6	1.7	1.7	0.0019	16	35	13.6	43.0	905	55.0	60.0	63.0	0.50	0.64	0.75	1.13
0.55	0.75	80	5.65	4.5	2.3	2.3	0.0030	10	22	17.0	43.0	930	60.0	65.0	67.0	0.50	0.63	0.73	1.62
0.75	1	90S	7.79	4.2	1.8	2.1	0.0044	17	37	18.0	45.0	920	68.0	70.0	70.0	0.51	0.65	0.75	2.06
1.1	1.5	90L	11.4	4.8	2.0	2.1	0.0060	9	20	24.5	45.0	925	70.0	72.0	73.0	0.47	0.60	0.72	3.02
1.5	2	100L	15.6	4.4	1.9	2.2	0.0093	21	46	31.0	44.0	920	76.0	77.0	76.0	0.52	0.66	0.73	3.90
2.2	3	112M	22.4	5.1	2.3	2.5	0.0165	17	37	43.0	48.0	940	78.0	78.5	78.0	0.53	0.66	0.74	5.50
3	4	132S	30.0	5.3	2.0	2.2	0.0340	20	44	64.0	53.0	955	81.0	82.0	81.0	0.58	0.70	0.77	6.94
4	5.5	132M	39.8	5.8	2.3	2.4	0.0435	19	42	68.0	53.0	960	81.0	82.5	82.5	0.54	0.66	0.74	9.46
5.5	7.5	132M	54.7	6.2	2.3	2.9	0.0606	19	42	81.0	52.0	960	82.5	84.5	84.5	0.51	0.64	0.72	13.0
7.5	10	160M	74.3	5.4	1.9	2.3	0.0966	12	26	122	56.0	965	85.3	85.5	85.3	0.64	0.76	0.83	15.3
9.2	12.5	160L	91.1	5.7	2.0	2.4	0.1229	10	22	132	56.0	965	86.0	86.5	86.0	0.66	0.76	0.83	18.6
11	15	160L	109	5.8	2.1	2.4	0.1489	11	24	146	56.0	965	87.0	87.5	87.2	0.65	0.77	0.83	21.9
15	20	180L	148	6.8	2.3	2.7	0.2299	6	13	195	56.0	970	88.0	88.5	88.2	0.72	0.82	0.87	28.2
18.5	25	200L	181	5.7	2.1	2.4	0.2989	12	26	231	60.0	975	88.3	89.3	88.9	0.64	0.76	0.82	36.6
22	30	200L	216	6.0	2.2	2.4	0.3692	13	29	259	60.0	975	89.5	90.0	89.7	0.67	0.77	0.83	42.7
30	40	225S/M	293	6.8	2.1	2.7	0.7192	12	26	400	63.0	980	91.0	91.5	91.2	0.74	0.83	0.86	55.2
37	50	250S/M	359	6.7	2.1	2.4	1.01	14	31	473	64.0	985	91.7	91.9	91.7	0.74	0.83	0.86	67.7
45	60	250S/M	437	6.5	2.1	2.3	1.28	15	33	514	64.0	985	92.2	92.4	92.2	0.75	0.84	0.87	81.0
High-Output Design																			
0.25	0.33	80	2.60	3.4	1.8	1.9	0.0015	26	57	10.0	43.0	920	51.0	58.0	60.0	0.52	0.65	0.76	0.791
0.75	1	90L	7.79	4.2	1.8	2.1	0.0044	17	37	20.5	45.0	920	68.0	70.0	70.0	0.51	0.65	0.75	2.06
1.5	2	112M	15.2	5.2	2.0	2.4	0.0147	21	46	42.0	48.0	945	75.5	77.5	77.0	0.53	0.66	0.75	3.75
3	4	112M	30.5	5.4	2.3	2.5	0.0257	15	33	48.0	48.0	940	81.0	82.5	82.0	0.55	0.68	0.75	7.04
3	4	132M	30.0	5.3	2.0	2.2	0.0340	20	44	64.0	53.0	955	81.0	82.0	81.0	0.58	0.70	0.77	6.94
4	5.5	132S	39.8	5.8	2.3	2.4	0.0435	19	42	68.0	53.0	960	81.0	82.5	82.5	0.54	0.66	0.74	9.46
7.5	10	160L	74.3	5.4	1.9	2.3	0.0966	12	26	122	56.0	965	85.3	85.5	85.3	0.64	0.76	0.83	15.3
11	15	160M	109	5.8	2.1	2.4	0.1489	11	24	146	56.0	965	87.0	87.5	87.2	0.65	0.77	0.83	21.9
15	20	180M	148	6.8	2.3	2.7	0.2299	6	13	195	56.0	970	88.0	88.5	88.2	0.72	0.82	0.87	28.2
18.5	25	200M	181	5.7	2.1	2.4	0.2989	12	26	231	60.0	975	88.3	89.3	88.9	0.64	0.76	0.82	36.6
22	30	200M	216	6.0	2.2	2.4	0.3692	13	29	259	60.0	975	89.5	90.0	89.7	0.67	0.77	0.83	42.7
37	50	225S/M	359	6.8	2.1	2.5	0.8876	11	24	435	63.0	985	91.7	91.9	91.7	0.74	0.83	0.86	67.7

Notes:

- (1) Efficiency values are given according to IEC 60034-2-1. They are calculated according to indirect method, with stray load losses determined by measurement.
- (2) With effect from 1st January 2015, IE1 motors placed onto the European Market their design falls outside of the scope of the European Regulation or their final installation will be outside of the EU / EEA.

Output		380 V								415 V							
		Rated speed (rpm)	% of full load						Full load current In (A)	Rated speed (rpm)	% of full load						Full load current In (A)
			Efficiency			Power factor					Efficiency			Power factor			
kW	HP	50	75	100	50	75	100	50	75	100	50	75	100	50	75	100	
VI pole - 1000 rpm - 50 Hz																	
0.12	0.16	845	48.5	50.9	50.1	0.47	0.59	0.72	0.504	860	38.5	43.1	45.7	0.43	0.52	0.63	0.577
0.18	0.25	885	49.3	55.1	55.9	0.41	0.52	0.62	0.789	905	42.9	50.5	53.7	0.37	0.46	0.55	0.848
0.25	0.33	880	51.8	57.3	57.6	0.41	0.53	0.63	1.05	905	45.0	52.6	55.5	0.36	0.45	0.54	1.16
0.37	0.5	890	57.0	62.0	65.0	0.54	0.69	0.80	1.08	910	55.0	60.0	62.0	0.47	0.60	0.72	1.15
0.55	0.75	920	62.0	65.8	68.0	0.54	0.67	0.77	1.60	935	58.0	64.0	66.0	0.47	0.59	0.68	1.70
0.75	1	905	70.1	70.6	70.0	0.56	0.70	0.78	2.09	925	65.9	69.1	70.1	0.47	0.61	0.71	2.10
1.1	1.5	915	70.7	74.3	76.1	0.52	0.67	0.77	2.85	930	68.8	69.5	73.0	0.42	0.55	0.67	3.13
1.5	2	910	77.6	77.2	75.2	0.57	0.70	0.76	3.99	925	74.4	76.3	76.3	0.48	0.62	0.70	3.91
2.2	3	930	79.8	78.9	77.7	0.58	0.71	0.78	5.52	945	76.0	77.4	77.9	0.48	0.62	0.71	5.53
3	4	950	81.0	83.0	82.0	0.61	0.72	0.79	7.04	960	80.0	82.0	81.1	0.53	0.66	0.74	6.95
4	5.5	960	82.0	82.5	82.5	0.58	0.73	0.78	9.44	965	80.0	82.2	83.4	0.52	0.64	0.72	9.27
5.5	7.5	955	83.8	85.1	84.4	0.56	0.69	0.76	13.0	965	81.1	83.8	84.3	0.47	0.60	0.69	13.2
7.5	10	960	86.2	85.6	84.7	0.69	0.80	0.85	15.8	970	84.3	85.2	85.4	0.60	0.73	0.81	15.1
9.2	12.5	960	86.8	86.6	85.8	0.71	0.79	0.85	19.2	970	85.1	86.2	86.2	0.62	0.73	0.81	18.3
11	15	960	87.6	87.5	86.6	0.69	0.80	0.85	22.7	970	86.4	87.3	87.4	0.61	0.74	0.81	21.6
15	20	970	88.5	88.4	87.7	0.76	0.85	0.89	29.2	970	87.4	88.3	88.4	0.68	0.79	0.85	27.8
18.5	25	970	89.3	89.6	88.7	0.70	0.80	0.85	37.3	975	87.3	88.8	88.8	0.59	0.72	0.79	36.7
22	30	970	90.3	90.2	89.4	0.72	0.81	0.85	44.0	975	88.6	89.6	89.7	0.62	0.73	0.81	42.1
30	40	975	91.2	91.3	90.7	0.78	0.85	0.87	57.8	980	90.6	91.4	91.2	0.71	0.81	0.85	53.8
37	50	980	91.9	91.7	91.2	0.77	0.85	0.87	70.9	985	91.4	91.9	91.8	0.71	0.81	0.85	66.0
45	60	980	92.2	92.1	91.6	0.78	0.86	0.88	84.8	985	92.0	92.4	92.2	0.72	0.82	0.86	79.0
High-Output Design																	
0.25	0.33	905	54.9	60.0	59.6	0.56	0.70	0.80	0.797	930	47.7	55.6	59.0	0.50	0.62	0.73	0.808
0.75	1	905	70.1	70.6	70.0	0.56	0.70	0.78	2.09	925	65.9	69.1	70.1	0.47	0.61	0.71	2.10
1.5	2	940	76.9	77.8	76.3	0.58	0.72	0.78	3.83	950	74.1	76.8	77.1	0.50	0.63	0.72	3.76
3	4	935	82.2	82.7	81.3	0.60	0.73	0.78	7.19	945	79.5	81.9	82.1	0.50	0.64	0.72	7.06
3	4	950	81.0	83.0	82.0	0.61	0.72	0.79	7.04	960	80.0	82.0	81.1	0.53	0.66	0.74	6.95
4	5.5	960	82.0	82.5	82.5	0.58	0.73	0.78	9.44	965	80.0	82.2	83.4	0.52	0.64	0.72	9.27
7.5	10	960	86.2	85.6	84.7	0.69	0.80	0.85	15.8	970	84.3	85.2	85.4	0.60	0.73	0.81	15.1
11	15	960	87.6	87.5	86.6	0.69	0.80	0.85	22.7	970	86.4	87.3	87.4	0.61	0.74	0.81	21.6
15	20	970	88.5	88.4	87.7	0.76	0.85	0.89	29.2	970	87.4	88.3	88.4	0.68	0.79	0.85	27.8
18.5	25	970	89.3	89.6	88.7	0.70	0.80	0.85	37.3	975	87.3	88.8	88.8	0.59	0.72	0.79	36.7
22	30	970	90.3	90.2	89.4	0.72	0.81	0.85	44.0	975	88.6	89.6	89.7	0.62	0.73	0.81	42.1
37	50	980	91.9	91.7	91.2	0.77	0.85	0.87	70.9	985	91.5	91.7	91.9	0.71	0.81	0.85	65.9

Performance Data

W22 Brake Motor - Standard Efficiency - IE1 ^{1) 2)}

Output		Frame	Full load torque (Nm)	Locked rotor current I _L /I _N	Locked rotor torque T _L /T _N	Breakdown torque T _b /T _N	Inertia J (kgm ²)	Allowable locked rotor time (s)		Weight (kg)	Sound dB (A)	400 V						Full load current I _N (A)	
								Hot	Cold			% of full load			Power factor				
												Rated speed (rpm)	Efficiency			Power factor			
kW	HP											50	75	100	50	75	100		
VIII pole - 750 rpm - 50 Hz																			
0.12	0.16	71	1.74	2.2	2.1	2.0	0.0008	84	185	12.2	41.0	660	36.3	43.4	45.6	0.37	0.45	0.53	0.717
0.18	0.25	80	2.47	2.8	2.2	2.4	0.0020	29	64	14.1	42.0	695	36.2	44.1	48.6	0.45	0.53	0.62	0.862
0.25	0.33	80	3.49	3.8	2.1	2.2	0.0027	27	59	14.5	42.0	685	46.0	51.0	53.0	0.45	0.56	0.66	1.03
0.37	0.5	90S	5.16	3.0	1.9	1.8	0.0038	32	70	17.9	43.0	685	50.6	56.5	57.4	0.44	0.55	0.64	1.45
0.55	0.75	90L	7.79	3.3	1.9	2.0	0.0058	25	55	19.0	43.0	675	58.0	60.0	60.0	0.43	0.56	0.66	2.01
0.75	1	100L	10.2	3.5	1.8	2.4	0.0077	33	73	27.8	50.0	705	62.0	67.2	67.8	0.42	0.53	0.62	2.58
1.1	1.5	100L	15.0	4.0	1.7	2.3	0.0116	27	59	32.5	50.0	700	69.3	72.3	71.2	0.45	0.57	0.66	3.38
1.5	2	112M	20.5	4.2	2.2	2.2	0.0174	26	57	39.4	46.0	700	73.7	75.4	73.5	0.48	0.61	0.70	4.21
2.2	3	132S	29.6	6.1	2.5	2.8	0.0592	22	48	64.3	48.0	710	75.8	78.0	77.1	0.55	0.68	0.77	5.35
3	4	132M	40.4	6.1	2.2	2.6	0.0715	18	40	74.0	48.0	710	78.5	80.1	79.0	0.55	0.68	0.76	7.21
4	5.5	160M	53.1	4.7	2.0	2.1	0.0878	17	37	120	51.0	720	79.5	82.0	81.5	0.52	0.65	0.72	9.84
5.5	7.5	160M	73.0	4.7	2.0	2.1	0.1141	16	35	129	51.0	720	82.0	83.2	83.0	0.52	0.65	0.73	13.1
7.5	10	160L	99.5	4.9	2.2	2.2	0.1492	16	35	149	51.0	720	84.0	85.5	85.0	0.52	0.65	0.73	17.4
9.2	12.5	180M	121	6.3	2.0	2.4	0.2037	10	22	185	51.0	725	86.0	86.5	86.0	0.64	0.76	0.82	18.8
11	15	180L	145	6.4	2.1	2.4	0.2444	10	22	204	51.0	725	87.0	87.5	87.0	0.67	0.78	0.84	21.7
15	20	200L	198	4.6	1.9	2.0	0.3341	22	48	246	53.0	725	87.5	88.0	88.0	0.58	0.70	0.76	32.4
18.5	25	225S/M	241	6.4	1.8	2.4	0.6183	18	40	384	56.0	735	91.0	91.0	90.6	0.66	0.77	0.82	35.9
22	30	225S/M	286	6.4	1.8	2.4	0.7214	16	35	403	56.0	735	91.3	91.3	91.0	0.69	0.79	0.83	42.0
30	40	250S/M	390	6.9	1.9	2.7	1.06	13	29	481	56.0	735	91.6	91.8	91.6	0.67	0.78	0.83	57.0
37	50	250S/M	484	6.9	1.9	2.7	1.33	12	26	523	56.0	730	91.9	92.0	91.9	0.67	0.78	0.83	70.0
High-Output Design																			
2.2	3	132M	29.6	6.1	2.5	2.8	0.0592	22	48	64.3	48.0	710	75.8	78.0	77.1	0.55	0.68	0.77	5.35
5.5	7.5	160L	73.0	4.7	2.0	2.1	0.1141	16	35	129	51.0	720	82.0	83.2	83.0	0.52	0.65	0.73	13.1
7.5	10	160M	99.5	4.9	2.2	2.2	0.1492	16	35	149	51.0	720	84.0	85.5	85.0	0.52	0.65	0.73	17.4
X pole - 600 rpm - 50 Hz																			
0.12	0.16	80	2.05	2.8	2.5	2.5	0.0030	45	99	17.0	42.0	560	36.0	43.0	47.0	0.40	0.45	0.52	0.709
0.18	0.25	90S	3.18	2.7	2.0	2.1	0.0046	50	110	21.5	43.0	540	40.0	48.0	48.0	0.39	0.47	0.59	0.917
0.25	0.33	90L	4.34	2.9	2.1	2.2	0.0055	33	73	22.0	43.0	550	39.0	46.0	48.0	0.38	0.47	0.55	1.37
0.37	0.5	100L	6.20	3.2	1.9	2.7	0.0099	45	99	29.5	50.0	570	52.0	61.0	61.0	0.30	0.35	0.42	2.08
0.55	0.75	112M	9.30	3.8	2.3	2.4	0.0165	50	110	36.0	46.0	565	60.0	65.0	65.0	0.36	0.45	0.53	2.30
0.75	1	132S	12.6	5.0	2.0	2.4	0.0444	40	88	49.0	48.0	570	70.0	74.0	74.0	0.40	0.52	0.60	2.44
1.1	1.5	132M	18.4	5.0	2.0	2.3	0.0542	30	66	60.0	50.0	570	75.0	77.0	77.0	0.42	0.54	0.63	3.27
1.5	2	132M	25.1	5.3	2.0	2.3	0.0641	30	66	0.0	48.0	570	71.0	75.0	76.0	0.44	0.56	0.64	4.45
2.2	3	160M	36.6	5.5	2.0	2.5	0.1237	20	44	104	51.0	575	77.0	79.0	79.0	0.52	0.65	0.73	5.51
3	4	160M	49.8	5.5	2.2	2.5	0.1502	15	33	124	51.0	575	78.0	79.0	80.0	0.50	0.62	0.72	7.52
4	5.5	180M	65.3	6.2	1.8	2.3	0.2177	23	51	179	51.0	585	84.8	86.4	86.1	0.55	0.68	0.75	8.94
5.5	7.5	180L	89.8	6.5	2.1	2.4	0.2857	27	59	199	51.0	585	85.3	86.9	86.6	0.55	0.67	0.75	12.3
7.5	10	200L	123	5.7	1.9	2.2	0.4126	38	84	279	53.0	585	85.3	86.9	86.6	0.52	0.64	0.70	17.9
9.2	12.5	225S/M	149	7.2	2.2	2.9	0.5505	24	53	355	56.0	590	86.2	88.7	89.2	0.50	0.62	0.70	21.3
11	15	225S/M	178	6.9	2.0	2.6	0.6193	23	51	375	56.0	590	87.5	89.4	89.6	0.54	0.66	0.73	24.3
15	20	250S/M	245	7.1	1.6	2.8	1.07	21	46	448	56.0	585	87.9	89.3	89.3	0.60	0.72	0.77	31.5
18.5	25	250S/M	302	7.3	1.8	2.9	1.20	21	46	448	56.0	585	88.5	89.8	89.3	0.59	0.70	0.76	39.1
High-Output Design																			
1.5	2	132S	25.1	5.3	2.0	2.3	0.0641	30	66	0.0	48.0	570	71.0	75.0	76.0	0.44	0.56	0.64	4.45
3	4	160L	49.8	5.5	2.2	2.5	0.1502	15	33	124	51.0	575	78.0	79.0	80.0	0.50	0.62	0.72	7.52
18.5	25	225S/M	302	5.7	1.8	2.5	0.9633	21	46	295	56.0	585	88.5	89.8	89.3	0.59	0.71	0.77	38.8

Notes:

- (1) Efficiency values are given according to IEC 60034-2-1. They are calculated according to indirect method, with stray load losses determined by measurement.
- (2) With effect from 1st January 2015, IE1 motors placed onto the European Market their design falls outside of the scope of the European Regulation or their final installation will be outside of the EU / EEA.

Output		380 V									415 V						
		Rated speed (rpm)	% of full load						Full load current In (A)	Rated speed (rpm)	% of full load						Full load current In (A)
			Efficiency			Power factor					Efficiency			Power factor			
kW	HP	50	75	100	50	75	100	50	75	100	50	75	100	50	75	100	
VIII pole - 750 rpm - 50 Hz																	
0.12	0.16	650	41.0	47.1	47.6	0.39	0.48	0.57	0.672	670	32.7	40.3	43.2	0.36	0.43	0.50	0.773
0.18	0.25	690	40.7	47.7	50.6	0.47	0.57	0.66	0.819	700	32.8	41.2	46.1	0.43	0.51	0.59	0.921
0.25	0.33	675	48.8	52.8	53.4	0.48	0.60	0.70	1.02	690	43.2	49.4	52.1	0.43	0.53	0.63	1.06
0.37	0.5	680	54.4	59.0	58.3	0.48	0.60	0.69	1.40	690	46.6	53.8	56.1	0.41	0.51	0.61	1.50
0.55	0.75	665	61.7	62.0	60.0	0.47	0.60	0.70	1.99	680	54.8	59.0	59.0	0.41	0.52	0.62	2.09
0.75	1	695	65.6	69.0	68.0	0.46	0.58	0.66	2.54	710	58.3	64.6	66.7	0.39	0.49	0.58	2.70
1.1	1.5	690	72.1	73.6	70.8	0.50	0.62	0.70	3.37	705	66.2	70.7	70.7	0.41	0.53	0.62	3.49
1.5	2	690	75.9	76.2	73.2	0.52	0.65	0.73	4.27	705	71.6	74.2	73.1	0.44	0.57	0.66	4.33
2.2	3	705	77.1	78.3	76.7	0.60	0.73	0.80	5.45	715	74.7	77.5	77.1	0.52	0.65	0.74	5.36
3	4	705	79.7	80.5	78.6	0.60	0.73	0.80	7.25	715	77.1	79.6	79.0	0.51	0.64	0.73	7.24
4	5.5	715	81.3	82.7	81.2	0.57	0.70	0.75	9.98	720	77.8	81.2	81.3	0.48	0.61	0.69	9.92
5.5	7.5	715	83.3	83.5	82.5	0.57	0.69	0.76	13.3	720	80.7	82.6	83.0	0.49	0.62	0.70	13.2
7.5	10	715	85.2	85.8	84.6	0.57	0.69	0.76	17.7	720	82.8	85.0	85.0	0.48	0.62	0.70	17.5
9.2	12.5	720	86.8	86.6	85.4	0.69	0.80	0.84	19.5	730	85.2	86.3	86.2	0.60	0.73	0.80	18.6
11	15	720	87.6	87.4	86.3	0.72	0.81	0.86	22.5	725	86.4	87.3	87.3	0.63	0.75	0.82	21.4
15	20	720	88.5	88.2	87.5	0.64	0.74	0.78	33.4	725	86.4	87.6	88.0	0.53	0.66	0.73	32.5
18.5	25	730	91.3	90.8	90.0	0.70	0.80	0.84	37.2	735	90.6	91.0	90.8	0.63	0.75	0.81	35.0
22	30	730	91.5	91.1	90.3	0.73	0.82	0.84	44.1	735	91.0	91.3	91.2	0.66	0.77	0.82	40.9
30	40	730	92.0	91.7	91.1	0.72	0.81	0.85	58.9	735	91.2	91.7	91.8	0.63	0.75	0.81	56.1
37	50	725	92.1	91.8	91.3	0.71	0.81	0.85	72.4	730	91.6	92.0	92.2	0.63	0.75	0.81	68.9
High-Output Design																	
2.2	3	705	77.1	78.3	76.7	0.60	0.73	0.80	5.45	715	74.7	77.5	77.1	0.52	0.65	0.74	5.36
5.5	7.5	715	83.3	83.5	82.5	0.57	0.69	0.76	13.3	720	80.7	82.6	83.0	0.49	0.62	0.70	13.2
7.5	10	715	85.2	85.8	84.6	0.57	0.69	0.76	17.7	720	82.8	85.0	85.0	0.48	0.62	0.70	17.5

X pole - 600 rpm - 50 Hz																	
kW	HP	Rated speed (rpm)	% of full load						Full load current In (A)	Rated speed (rpm)	% of full load						Full load current In (A)
		Rated speed (rpm)	Efficiency			Power factor			Full load current In (A)	Rated speed (rpm)	Efficiency			Power factor			Full load current In (A)
kW	HP		50	75	100	50	75	100			50	75	100	50	75	100	
0.12	0.16	555	38.0	45.0	48.0	0.41	0.47	0.54	0.703	565	33.0	40.0	44.0	0.38	0.44	0.50	0.759
0.18	0.25	535	42.0	48.0	48.5	0.40	0.49	0.60	0.940	545	43.0	48.0	48.5	0.38	0.45	0.54	0.956
0.25	0.33	545	40.0	47.0	49.5	0.39	0.49	0.58	1.32	555	36.0	44.0	47.0	0.37	0.45	0.52	1.42
0.37	0.5	565	55.0	60.0	60.0	0.32	0.40	0.47	1.99	570	52.5	62.0	63.0	0.28	0.34	0.41	1.99
0.55	0.75	560	61.0	66.0	66.0	0.38	0.48	0.56	2.26	570	60.0	65.0	65.0	0.34	0.42	0.50	2.35
0.75	1	570	74.0	76.0	76.0	0.44	0.55	0.64	2.34	575	70.0	74.0	74.0	0.38	0.49	0.57	2.47
1.1	1.5	565	75.0	77.0	77.0	0.46	0.58	0.66	3.29	570	73.0	76.0	76.0	0.40	0.51	0.60	3.36
1.5	2	560	72.5	75.5	76.0	0.47	0.59	0.67	4.48	570	72.0	75.0	77.0	0.41	0.52	0.61	4.44
2.2	3	570	77.0	78.0	78.0	0.55	0.69	0.75	5.71	575	80.0	81.0	81.0	0.50	0.63	0.71	5.32
3	4	570	77.5	79.0	79.5	0.53	0.65	0.73	7.85	575	79.0	80.0	80.0	0.48	0.60	0.70	7.45
4	5.5	580	85.5	86.5	85.5	0.59	0.71	0.77	9.23	585	84.2	86.3	86.3	0.52	0.66	0.74	8.71
5.5	7.5	585	85.9	86.9	86.0	0.58	0.70	0.76	12.7	585	84.8	86.8	86.9	0.52	0.65	0.73	12.1
7.5	10	585	85.9	86.9	86.0	0.56	0.67	0.72	18.4	585	84.8	86.8	86.9	0.48	0.60	0.67	17.9
9.2	12.5	590	87.4	89.2	89.4	0.55	0.67	0.73	21.4	590	85.0	87.9	88.8	0.46	0.58	0.66	21.9
11	15	590	88.4	89.8	89.6	0.60	0.70	0.76	24.5	590	86.5	88.9	89.4	0.50	0.62	0.70	24.5
15	20	585	88.3	89.3	88.9	0.64	0.74	0.79	32.5	585	87.4	89.2	89.5	0.57	0.69	0.75	31.1
18.5	25	585	89.0	89.8	89.0	0.63	0.73	0.78	40.3	586	87.9	89.6	89.4	0.55	0.67	0.74	38.7
High-Output Design																	
1.5	2	560	72.5	75.5	76.0	0.47	0.59	0.67	4.48	570	72.0	75.0	77.0	0.41	0.52	0.61	4.44
3	4	570	77.5	79.0	79.5	0.53	0.65	0.73	7.85	575	79.0	80.0	80.0	0.48	0.60	0.70	7.45
18.5	25	585	89.0	89.8	89.0	0.63	0.74	0.78	40.5	590	87.9	89.6	89.4	0.56	0.69	0.75	38.4

Performance Data

W22 Brake Motor - Standard Efficiency - IE1 ^{1) 2)}

Output		Frame	Full load torque (Nm)	Locked rotor current I _L /I _n	Locked rotor torque T _L /T _n	Breakdown torque T _b /T _n	Inertia J (kgm ²)	Allowable locked rotor time (s)		Weight (kg)	Sound dB (A)	Rated speed (rpm)	400 V						Full load current I _n (A)
								Hot	Cold				% of full load			Power factor			
													Efficiency	Power factor					
kW	HP											50	75	100	50	75	100		
XII pole - 500 rpm - 50 Hz																			
0.12	0.16	90S	2.49	2.3	1.8	2.0	0.0049	51	112	17.0	43.0	460	26.0	32.0	37.0	0.35	0.40	0.46	1.02
0.18	0.25	90L	3.74	2.3	1.8	2.0	0.0066	45	99	22.5	43.0	460	30.0	36.0	40.0	0.33	0.39	0.45	1.44
0.25	0.33	100L	5.03	2.6	2.0	2.5	0.0099	80	176	29.0	50.0	475	37.0	45.0	49.0	0.27	0.32	0.38	1.94
0.37	0.5	112M	7.52	3.0	2.0	2.3	0.0183	50	110	39.0	46.0	470	42.0	51.0	55.0	0.32	0.38	0.45	2.16
0.55	0.75	132S	11.0	4.1	2.3	2.6	0.0493	60	132	54.0	48.0	480	56.0	63.0	66.0	0.31	0.39	0.48	2.51
0.75	1	132M	14.9	4.1	2.3	2.6	0.0592	50	110	65.0	48.0	480	56.0	63.0	66.0	0.31	0.40	0.48	3.42
1.1	1.5	132M	22.1	4.4	2.3	2.5	0.0740	43	95	79.0	48.0	475	60.0	65.0	68.0	0.32	0.42	0.50	4.67
1.5	2	160M	29.6	3.7	2.0	2.3	0.1149	60	132	117	51.0	485	65.0	72.0	74.0	0.35	0.44	0.51	5.74
2.2	3	160L	43.3	3.5	1.9	2.0	0.1325	60	132	119	51.0	485	70.0	74.0	76.0	0.38	0.48	0.55	7.60
3	4	180L	59.1	6.0	2.1	2.0	0.2449	21	46	185	51.0	485	72.0	78.0	80.0	0.47	0.58	0.65	8.33
4	5.5	180L	78.8	6.0	2.0	2.0	0.2857	21	46	197	51.0	485	74.0	79.0	81.0	0.48	0.59	0.66	10.8
5.5	7.5	200L	107	6.0	1.8	3.0	0.3713	26	57	256	53.0	490	75.0	80.0	82.0	0.48	0.60	0.68	14.2
7.5	10	225S/M	146	6.0	1.8	2.4	0.6193	25	55	384	56.0	490	83.0	85.0	86.0	0.45	0.58	0.66	19.1
9.2	12.5	225S/M	179	6.0	1.9	2.5	0.6193	24	53	395	56.0	490	84.0	86.0	87.0	0.44	0.57	0.65	23.5
11	15	250S/M	215	6.5	2.0	2.5	1.20	38	84	488	56.0	490	85.0	87.0	88.0	0.47	0.60	0.67	26.9
15	20	250S/M	296	6.0	1.9	2.3	1.25	29	64	528	56.0	485	85.0	87.0	88.0	0.49	0.61	0.68	36.2
High-Output Design																			
11	15	225S/M	215	6.0	1.8	2.4	0.8945	28	62	485	56.0	490	85.0	87.0	88.0	0.47	0.60	0.67	26.9

Notes:
 (1) Efficiency values are given according to IEC 60034-2-1. They are calculated according to indirect method, with stray load losses determined by measurement.
 (2) With effect from 1st January 2015, IE1 motors placed onto the European Market their design falls outside of the scope of the European Regulation or their final installation will be outside of the EU / EEA.

Output		380 V								415 V							
		Rated speed (rpm)	% of full load						Full load current In (A)	Rated speed (rpm)	% of full load						Full load current In (A)
			Efficiency			Power factor					Efficiency			Power factor			
kW	HP	50	75	100	50	75	100	50	75	100	50	75	100	50	75	100	
XII pole - 500 rpm - 50 Hz																	
0.12	0.16	455	28.0	33.5	38.0	0.36	0.41	0.48	1.00	460	25.0	30.5	36.0	0.34	0.38	0.44	1.05
0.18	0.25	455	32.0	38.0	41.5	0.35	0.42	0.47	1.40	460	28.0	34.0	38.5	0.32	0.37	0.43	1.51
0.25	0.33	475	39.0	47.0	50.0	0.28	0.35	0.41	1.85	480	34.5	43.0	47.5	0.26	0.31	0.36	2.03
0.37	0.5	465	44.5	53.0	56.5	0.33	0.40	0.48	2.07	470	40.0	49.0	54.0	0.30	0.36	0.42	2.27
0.55	0.75	475	58.5	65.0	67.0	0.33	0.42	0.51	2.45	480	64.0	61.0	65.0	0.29	0.36	0.45	2.62
0.75	1	475	59.0	65.0	67.5	0.33	0.43	0.51	3.31	480	54.0	61.5	65.0	0.29	0.37	0.45	3.57
1.1	1.5	475	62.5	66.5	69.0	0.34	0.45	0.54	4.49	480	57.5	63.0	67.0	0.29	0.39	0.46	4.97
1.5	2	485	67.0	73.5	75.0	0.37	0.47	0.54	5.63	485	63.5	71.0	73.5	0.32	0.41	0.48	5.91
2.2	3	480	71.5	75.0	76.0	0.41	0.51	0.58	7.58	485	68.5	73.0	75.5	0.35	0.45	0.52	7.80
3	4	480	73.0	78.5	80.0	0.50	0.61	0.67	8.50	485	71.0	77.5	79.5	0.44	0.56	0.63	8.33
4	5.5	480	75.0	79.5	81.0	0.51	0.61	0.68	11.0	485	73.0	78.5	80.5	0.45	0.57	0.64	10.8
5.5	7.5	485	76.5	81.0	81.5	0.50	0.62	0.70	14.6	490	73.5	80.0	82.5	0.45	0.55	0.65	14.3
7.5	10	490	83.5	85.0	86.0	0.47	0.60	0.68	19.5	490	82.0	85.0	86.5	0.42	0.55	0.63	19.1
9.2	12.5	485	84.5	86.0	87.0	0.48	0.60	0.68	23.6	490	82.5	85.0	86.5	0.40	0.53	0.62	23.9
11	15	485	85.5	87.0	88.0	0.51	0.63	0.70	27.1	490	84.0	86.5	87.5	0.44	0.56	0.64	27.3
15	20	485	85.5	87.0	88.0	0.53	0.65	0.71	36.5	490	84.0	86.5	87.5	0.45	0.57	0.65	36.7
High-Output Design																	
11	15	485	85.5	87.0	88.0	0.51	0.63	0.70	27.1	490	84.0	86.5	87.5	0.44	0.56	0.64	27.3



Performance Data

W22 Brake Motor - High Efficiency - IE2

Output		Frame	Full load torque (Nm)	Locked rotor current I _L /I _n	Locked rotor torque T _L /T _n	Breakdown torque T _b /T _n	Inertia J (kgm ²)	Allowable locked rotor time (s)		Weight (kg)	Sound dB (A)	400 V							Full load current I _n (A)
								Rated speed (rpm)	% of full load										
									Efficiency			Power factor							
kW	HP							Hot	Cold			50	75	100	50	75	100		
II pole - 3000 rpm - 50 Hz																			
0.12	0.16	63	0.410	4.8	3.0	2.9	0.0001	37	81	6.7	52.0	2790	53.0	60.0	61.0	0.53	0.66	0.75	0.379
0.18	0.25	63	0.620	5.3	2.3	2.4	0.0001	15	33	7.2	52.0	2790	57.0	62.0	64.0	0.57	0.70	0.79	0.510
0.25	0.33	63	0.860	5.0	2.2	2.2	0.0002	11	24	7.7	52.0	2770	58.0	63.0	65.0	0.57	0.70	0.80	0.690
0.37	0.5	71	1.25	5.8	2.5	2.6	0.0004	12	26	9.8	56.0	2830	68.0	70.0	71.0	0.60	0.75	0.84	0.895
0.55	0.75	71	1.89	5.8	2.4	2.4	0.0005	9	20	11.5	56.0	2780	70.0	72.0	72.0	0.68	0.82	0.88	1.25
0.75	1	80	2.56	6.5	2.8	2.8	0.0008	14	31	14.0	59.0	2800	76.0	78.5	79.5	0.67	0.80	0.86	1.58
1.1	1.5	80	3.75	6.5	2.8	2.8	0.0009	10	22	15.5	59.0	2800	78.0	80.0	80.0	0.67	0.79	0.85	2.33
1.5	2	90S	5.06	7.0	2.6	2.8	0.0021	7	15	20.0	62.0	2835	80.0	82.0	82.0	0.63	0.76	0.83	3.14
2.2	3	90L	7.40	6.6	3.0	3.0	0.0022	9	20	23.5	64.0	2840	83.0	83.6	83.6	0.63	0.76	0.83	4.58
3	4	100L	9.95	8.0	2.4	2.8	0.0064	7	15	32.5	67.0	2880	84.0	85.0	85.0	0.70	0.81	0.86	5.92
4	5.5	112M	13.3	7.0	2.0	2.8	0.0088	10	22	44.0	64.0	2880	86.0	86.0	86.0	0.73	0.83	0.88	7.63
5.5	7.5	132S	18.1	6.8	2.2	3.0	0.0197	17	37	69.0	67.0	2910	86.5	88.0	88.0	0.68	0.79	0.85	10.6
7.5	10	132S	24.6	6.8	2.2	2.9	0.0251	13	29	72.0	68.0	2910	88.0	88.5	88.5	0.72	0.82	0.87	14.1
9.2	12.5	132M	30.2	7.6	2.5	3.2	0.0234	10	22	72.0	68.0	2915	88.5	89.0	89.0	0.70	0.81	0.86	17.3
11	15	160M	35.8	7.0	2.3	3.0	0.0446	13	29	123	67.0	2935	90.0	90.6	90.5	0.71	0.82	0.86	20.4
15	20	160M	48.9	7.0	2.3	3.0	0.0517	9	20	131	67.0	2930	91.0	91.3	91.3	0.71	0.81	0.86	27.6
18.5	25	160L	60.1	7.4	2.4	3.1	0.0625	8	18	143	67.0	2940	91.3	92.0	92.0	0.70	0.80	0.86	33.7
22	30	180M	71.4	7.3	2.2	3.0	0.0975	9	20	193	67.0	2945	92.0	92.4	92.2	0.76	0.84	0.88	39.1
30	40	200L	97.0	6.5	2.4	2.7	0.1703	17	37	267	72.0	2955	92.5	93.0	92.9	0.75	0.83	0.87	53.6
37	50	200L	120	6.8	2.4	2.6	0.1950	16	35	296	72.0	2950	93.0	93.4	93.3	0.76	0.84	0.87	65.8
45	60	200L	146	6.6	2.1	2.4	0.2204	15	33	313	72.0	2955	92.5	92.9	92.9	0.76	0.84	0.87	80.4
High-Output Design																			
0.37	0.5	63	1.29	5.0	2.2	2.2	0.0002	7	15	8.2	52.0	2740	64.0	67.0	68.0	0.56	0.71	0.81	0.970
0.75	1	71	2.59	5.8	2.8	2.8	0.0005	14	31	10.5	56.0	2770	77.0	77.5	77.6	0.67	0.80	0.87	1.60
0.75	1	90S	2.51	6.5	2.7	2.8	0.0012	25	55	18.0	64.0	2850	77.0	79.0	79.0	0.61	0.73	0.80	1.71
1.1	1.5	90S	3.71	6.1	2.5	2.6	0.0014	16	35	19.0	64.0	2835	80.0	80.5	80.5	0.65	0.77	0.83	2.38
1.5	2	80	5.17	6.5	3.1	3.0	0.0009	15	33	16.5	59.0	2770	80.0	81.0	81.5	0.65	0.78	0.85	3.13
1.5	2	90L	5.00	7.0	2.6	2.8	0.0021	7	15	20.0	64.0	2865	80.0	82.0	82.0	0.63	0.76	0.83	3.14
2.2	3	100L	7.29	7.5	2.6	3.0	0.0043	15	33	30.5	67.0	2885	82.5	83.6	83.6	0.66	0.78	0.85	4.47
4	5.5	100L	13.3	7.8	3.0	3.4	0.0064	10	22	36.0	67.0	2870	85.2	85.8	85.8	0.67	0.80	0.86	7.82
5.5	7.5	112M	18.3	7.3	2.7	3.0	0.0088	11	24	48.0	64.0	2880	86.5	87.0	87.0	0.72	0.82	0.87	10.5
5.5	7.5	132M	18.1	6.8	2.2	3.0	0.0197	17	37	69.0	67.0	2910	86.5	88.0	88.0	0.68	0.79	0.85	10.6
7.5	10	132M	24.6	6.8	2.2	2.9	0.0251	13	29	72.0	68.0	2910	88.0	88.5	88.5	0.72	0.82	0.87	14.1
11	15	132M	36.2	7.2	2.4	2.9	0.0270	11	24	83.0	68.0	2905	89.3	89.6	89.6	0.75	0.84	0.88	20.1
11	15	160L	35.8	7.0	2.3	3.0	0.0446	13	29	123	67.0	2935	90.0	90.6	90.5	0.71	0.82	0.86	20.4
15	20	160L	48.9	7.0	2.3	3.0	0.0517	9	20	131	67.0	2930	91.0	91.3	91.3	0.71	0.81	0.86	27.6
18.5	25	180M	60.1	7.0	2.1	2.9	0.0867	10	22	185	67.0	2940	91.4	92.0	91.8	0.75	0.84	0.88	33.1
22	30	160L	71.6	7.9	2.5	3.1	0.0813	10	22	159	67.0	2935	91.2	91.6	91.6	0.75	0.84	0.89	39.0
22	30	180L	71.4	7.3	2.2	3.0	0.0975	9	20	193	67.0	2945	92.0	92.4	92.2	0.76	0.84	0.88	39.1
30	40	180L	97.5	8.2	2.2	2.9	0.1301	8	18	223	76.0	2940	91.5	92.0	92.0	0.78	0.86	0.89	52.9

Notes:

(1) Efficiency values are given according to IEC 60034-2-1. They are calculated according to indirect method, with stray load losses determined by measurement.

(2) With effect from 1st January 2015, IE2 motors placed onto the European Market and rated at 7.5kw or above, must be used with a variable speed drive unless their design falls outside of the scope of the European Regulation or their final installation will be outside of the EU / EEA.

Output		380 V								415 V							
		Rated speed (rpm)	% of full load						Full load current In (A)	Rated speed (rpm)	% of full load						Full load current In (A)
			Efficiency			Power factor					Efficiency			Power factor			
kW	HP	50	75	100	50	75	100	50	75	100	50	75	100	50	75	100	
II pole - 3000 rpm - 50 Hz																	
0.12	0.16	2765	54.7	60.8	60.9	0.57	0.71	0.79	0.379	2805	51.4	59.0	60.6	0.50	0.63	0.72	0.383
0.18	0.25	2760	58.0	63.0	64.0	0.61	0.75	0.83	0.510	2805	55.0	60.9	63.6	0.53	0.66	0.76	0.514
0.25	0.33	2740	60.3	64.1	65.0	0.63	0.76	0.84	0.690	2785	55.9	61.7	64.5	0.53	0.66	0.76	0.752
0.37	0.5	2805	69.0	70.1	70.3	0.66	0.79	0.87	0.900	2845	66.9	69.7	71.2	0.57	0.72	0.82	0.882
0.55	0.75	2750	70.8	71.9	71.0	0.73	0.85	0.91	1.29	2795	68.9	71.7	72.5	0.63	0.79	0.86	1.23
0.75	1	2770	77.7	78.0	78.0	0.66	0.81	0.87	1.68	2810	75.0	78.5	79.5	0.64	0.77	0.84	1.56
1.1	1.5	2775	78.9	79.2	79.6	0.73	0.83	0.87	2.43	2815	77.1	80.2	80.2	0.62	0.75	0.82	2.33
1.5	2	2810	80.5	81.6	81.6	0.68	0.79	0.85	3.25	2850	79.3	81.9	82.5	0.58	0.73	0.81	3.08
2.2	3	2820	83.7	83.5	83.2	0.69	0.80	0.85	4.75	2855	82.2	83.4	83.9	0.59	0.72	0.80	4.56
3	4	2865	84.9	85.0	85.0	0.76	0.85	0.88	6.09	2890	83.1	84.6	85.0	0.66	0.78	0.84	5.85
4	5.5	2865	86.6	86.0	85.8	0.78	0.87	0.90	7.90	2890	85.3	85.9	86.3	0.69	0.80	0.86	7.50
5.5	7.5	2900	87.1	88.0	87.6	0.74	0.83	0.88	10.8	2915	85.6	87.6	88.0	0.63	0.76	0.83	10.5
7.5	10	2900	88.4	88.4	88.1	0.77	0.85	0.89	14.5	2915	87.3	88.3	88.7	0.67	0.79	0.85	13.8
9.2	12.5	2905	89.1	89.0	89.0	0.75	0.85	0.89	17.6	2920	87.6	88.6	89.0	0.65	0.77	0.84	17.1
11	15	2930	90.3	90.5	90.1	0.75	0.85	0.88	21.1	2940	89.6	90.5	90.6	0.67	0.79	0.84	20.1
15	20	2945	91.4	91.3	90.9	0.76	0.84	0.88	28.5	2935	90.6	91.2	91.4	0.67	0.78	0.84	27.2
18.5	25	2930	91.6	91.9	91.6	0.74	0.83	0.88	34.9	2945	91.0	91.9	92.2	0.66	0.77	0.84	33.2
22	30	2940	92.2	92.2	91.8	0.79	0.86	0.89	40.9	2950	91.8	92.4	92.4	0.73	0.82	0.87	38.1
30	40	2950	92.7	92.9	92.6	0.79	0.85	0.88	55.9	2960	92.3	93.0	93.0	0.71	0.81	0.86	52.2
37	50	2945	93.2	93.3	93.0	0.80	0.86	0.88	68.7	2955	92.8	93.4	93.5	0.73	0.82	0.86	64.0
45	60	2950	92.6	92.9	92.9	0.80	0.87	0.89	82.7	2960	92.4	93.0	92.9	0.72	0.82	0.86	78.4
High-Output Design																	
0.37	0.5	2705	65.0	67.6	67.4	0.62	0.76	0.83	1.00	2760	61.1	66.2	67.9	0.52	0.66	0.77	0.980
0.75	1	2750	77.0	77.4	77.4	0.73	0.84	0.90	1.64	2890	76.0	77.6	77.6	0.62	0.76	0.85	1.58
0.75	1	2830	77.8	79.1	78.3	0.66	0.77	0.83	1.75	2860	76.0	78.7	79.2	0.56	0.70	0.78	1.69
1.1	1.5	2810	80.7	80.3	79.6	0.70	0.80	0.85	2.47	2850	79.2	80.4	81.0	0.60	0.74	0.81	2.33
1.5	2	2750	81.0	81.5	81.3	0.71	0.83	0.88	3.19	2790	80.0	81.0	81.7	0.59	0.74	0.82	3.11
1.5	2	2840	80.5	81.6	81.6	0.68	0.79	0.85	3.25	2880	79.3	81.9	82.5	0.58	0.73	0.81	3.08
2.2	3	2870	83.3	83.8	83.2	0.71	0.82	0.87	4.62	2895	81.5	83.2	83.6	0.62	0.75	0.82	4.46
4	5.5	2860	85.5	85.8	85.8	0.73	0.83	0.88	8.05	2880	85.0	86.0	86.0	0.63	0.76	0.83	7.80
5.5	7.5	2865	87.0	86.9	87.0	0.76	0.86	0.89	10.8	2885	85.9	86.8	87.2	0.67	0.79	0.85	10.3
5.5	7.5	2900	87.1	88.0	87.6	0.74	0.83	0.88	10.8	2915	85.6	87.6	88.0	0.63	0.76	0.83	10.5
7.5	10	2900	88.4	88.4	88.1	0.77	0.85	0.89	14.5	2915	87.3	88.3	88.7	0.67	0.79	0.85	13.8
11	15	2895	89.7	89.5	89.6	0.79	0.87	0.89	21.1	2910	88.7	89.4	89.8	0.71	0.81	0.86	19.8
11	15	2930	90.3	90.5	90.1	0.75	0.85	0.88	21.1	2940	89.6	90.5	90.6	0.67	0.79	0.84	20.1
15	20	2945	91.4	91.3	90.9	0.76	0.84	0.88	28.5	2935	90.6	91.2	91.4	0.67	0.78	0.84	27.2
18.5	25	2935	91.6	91.8	91.4	0.78	0.86	0.89	34.6	2945	91.2	92.0	92.0	0.72	0.82	0.87	32.2
22	30	2930	91.2	91.6	91.5	0.79	0.87	0.90	40.6	2940	91.0	91.6	91.8	0.72	0.82	0.87	38.3
22	30	2940	92.2	92.2	91.8	0.79	0.86	0.89	40.9	2950	91.8	92.4	92.4	0.73	0.82	0.87	38.1
30	40	2935	91.5	92.0	92.0	0.81	0.88	0.90	55.0	2945	91.8	92.3	92.3	0.75	0.84	0.88	51.4

Performance Data

W22 Brake Motor - High Efficiency - IE2

Output		Frame	Full load torque (Nm)	Locked rotor current I _L /I _N	Locked rotor torque T _L /T _N	Breakdown torque T _b /T _n	Inertia J (kgm ²)	Allowable locked rotor time (s)		Weight (kg)	Sound dB (A)	400 V								
								Rated speed (rpm)	% of full load			Full load current I _N (A)								
									Efficiency				Power factor							
kW	HP							Hot	Cold			50	75	100	50	75	100			
IV pole - 1500 rpm - 50 Hz																				
0.12	0.16	63	0.830	3.9	1.8	2.0	0.0004	51	112	8.0	44.0	1380	55.0	58.0	59.1	0.54	0.67	0.77	0.381	
0.18	0.25	63	1.26	4.1	2.0	2.0	0.0006	40	88	8.2	44.0	1370	53.0	59.0	61.0	0.50	0.63	0.72	0.592	
0.25	0.33	71	1.71	4.5	2.0	2.2	0.0007	68	150	11.7	43.0	1400	59.0	65.0	68.5	0.49	0.62	0.71	0.742	
0.37	0.5	71	2.56	4.3	2.0	2.0	0.0008	48	106	12.3	43.0	1380	63.0	66.0	68.0	0.50	0.64	0.74	1.06	
0.55	0.75	80	3.70	6.0	2.1	2.5	0.0029	18	40	16.5	44.0	1420	72.0	73.8	77.1	0.60	0.73	0.82	1.26	
0.75	1	80	5.08	6.0	2.6	2.6	0.0029	15	33	16.5	44.0	1410	79.0	79.6	79.8	0.63	0.76	0.81	1.63	
1.1	1.5	90S	7.30	6.5	2.1	2.6	0.0049	14	31	23.3	49.0	1440	81.0	81.8	81.8	0.62	0.75	0.81	2.40	
1.5	2	90L	9.95	6.3	2.0	2.8	0.0055	10	22	24.5	49.0	1440	81.5	83.0	83.0	0.57	0.71	0.80	3.26	
2.2	3	100L	14.7	7.0	3.1	3.2	0.0105	11	24	38.0	53.0	1435	83.0	84.5	84.5	0.60	0.73	0.81	4.64	
3	4	100L	20.2	6.5	3.2	3.3	0.0097	14	31	38.0	53.0	1420	85.0	85.6	85.6	0.63	0.75	0.82	6.17	
4	5.5	112M	26.5	6.6	2.0	2.6	0.0156	13	29	49.0	56.0	1440	86.0	86.7	86.7	0.62	0.74	0.80	8.32	
5.5	7.5	132S	36.0	7.3	1.9	3.0	0.0528	8	18	76.0	60.0	1460	87.5	88.0	88.1	0.68	0.80	0.86	10.5	
7.5	10	132M	49.3	7.2	2.0	3.0	0.0528	8	18	77.0	60.0	1455	88.7	89.0	89.0	0.71	0.81	0.86	14.1	
9.2	12.5	132M	60.4	7.7	2.2	3.2	0.0604	7	15	84.0	60.0	1455	89.2	89.5	89.5	0.69	0.80	0.85	17.3	
11	15	160M	71.5	6.4	2.3	2.8	0.1048	10	22	124	61.0	1470	89.0	90.2	90.2	0.65	0.76	0.83	21.2	
15	20	160L	97.8	6.2	2.3	2.8	0.1255	10	22	144	61.0	1465	90.6	91.0	91.0	0.66	0.76	0.83	28.7	
18.5	25	180M	121	6.6	2.4	2.8	0.1657	14	31	193	61.0	1465	91.5	91.8	91.6	0.68	0.78	0.83	35.1	
22	30	180L	143	6.8	2.6	2.9	0.2006	15	33	215	61.0	1465	92.2	92.5	92.3	0.70	0.80	0.85	40.5	
30	40	200L	195	6.3	2.2	2.6	0.2929	16	35	263	65.0	1470	92.6	93.0	92.8	0.68	0.78	0.83	56.2	
37	50	225S/M	240	6.6	2.2	2.7	0.4438	12	26	387	66.0	1475	93.0	93.2	93.2	0.74	0.83	0.86	66.6	
45	60	225S/M	292	6.8	2.4	2.7	0.5177	10	22	408	66.0	1475	93.2	93.7	93.6	0.74	0.83	0.86	80.7	
55	75	250S/M	356	6.4	2.2	2.7	0.8118	14	31	492	66.0	1475	93.6	93.9	94.0	0.75	0.84	0.87	97.1	
75	100	250S/M	486	7.2	2.4	2.9	1.05	10	22	544	66.0	1475	94.0	94.3	94.4	0.74	0.84	0.88	130	
High-Output Design																				
0.25	0.33	80	1.68	5.5	2.0	2.5	0.0015	31	68	10.5	44.0	1420	70.0	74.0	74.0	0.61	0.74	0.81	0.602	
0.37	0.5	80	2.49	5.7	2.2	2.7	0.0019	23	51	11.0	44.0	1420	73.0	75.5	75.5	0.60	0.73	0.81	0.873	
0.55	0.75	71	3.92	4.1	2.4	2.2	0.0008	29	64	13.0	43.0	1340	68.0	70.5	70.5	0.50	0.64	0.74	1.52	
0.75	1	90S	5.03	5.9	2.2	2.6	0.0038	19	42	20.5	49.0	1425	78.0	80.0	80.0	0.59	0.72	0.80	1.69	
1.1	1.5	90L	7.25	6.5	2.1	2.6	0.0060	9	20	25.5	49.0	1450	80.0	81.8	81.8	0.53	0.68	0.78	2.49	
1.5	2	100L	10.1	6.6	2.8	3.0	0.0067	20	44	28.0	53.0	1425	82.5	83.2	83.2	0.62	0.74	0.81	3.21	
2.2	3	112M	14.4	7.0	1.9	2.6	0.0117	23	51	45.0	56.0	1460	84.5	85.0	85.0	0.63	0.75	0.81	4.61	
4	5.5	132M	26.3	7.2	1.9	3.0	0.0341	14	31	69.0	60.0	1455	87.0	87.2	87.2	0.68	0.80	0.85	7.75	
4	5.5	132S	26.3	7.2	1.9	3.0	0.0341	14	31	69.0	60.0	1455	87.0	87.2	87.2	0.68	0.80	0.85	7.75	
5.5	7.5	132M	36.0	7.3	1.9	3.0	0.0528	8	18	76.0	60.0	1460	87.5	88.0	88.1	0.68	0.80	0.86	10.5	
7.5	10	132S	49.3	7.2	2.0	3.0	0.0528	8	18	77.0	60.0	1455	88.7	89.0	89.0	0.71	0.81	0.86	14.1	
7.5	10	160M	48.9	6.1	2.1	2.7	0.0769	15	33	112	61.0	1465	88.0	89.2	89.0	0.65	0.77	0.83	14.7	
9.2	12.5	160M	60.0	6.0	2.0	2.6	0.0838	13	29	115	61.0	1465	88.5	89.5	89.3	0.66	0.77	0.83	17.9	
11	15	132M/L*	72.2	7.7	2.4	3.2	0.0676	7	15	93.0	56.0	1455	89.0	89.5	89.8	0.65	0.77	0.84	21.0	
11	15	160L	71.5	6.4	2.3	2.8	0.1048	10	22	124	61.0	1470	89.0	90.2	90.2	0.65	0.76	0.83	21.2	
15	20	180L	97.8	6.6	2.4	2.9	0.1401	14	31	181	61.0	1465	90.8	91.5	91.3	0.66	0.77	0.83	28.6	
15	20	180M	97.8	6.6	2.4	2.9	0.1401	14	31	181	61.0	1465	90.8	91.5	91.3	0.66	0.77	0.83	28.6	
18.5	25	160L	121	6.7	2.5	2.8	0.1607	9	20	159	61.0	1465	90.5	91.0	91.2	0.66	0.78	0.83	35.3	
18.5	25	180L	121	6.6	2.4	2.8	0.1657	14	31	193	61.0	1465	91.5	91.8	91.6	0.68	0.78	0.83	35.1	
22	30	180M	143	6.8	2.6	2.9	0.2006	15	33	215	61.0	1465	92.2	92.5	92.3	0.70	0.80	0.85	40.5	
30	40	180L	196	6.5	2.5	2.6	0.2393	14	31	239	61.0	1465	91.6	92.0	92.3	0.68	0.78	0.83	56.5	
37	50	200L	241	6.0	2.1	2.5	0.3721	14	31	278	65.0	1470	92.8	93.0	93.0	0.70	0.80	0.83	69.2	
45	60	200L*	293	6.5	2.3	2.6	0.3721	9	20	316	65.0	1470	92.7	93.0	93.1	0.65	0.76	0.82	85.1	
55	75	225S/M	356	6.9	2.3	2.6	0.6880	15	33	465	66.0	1475	92.8	93.2	93.5	0.74	0.83	0.86	98.7	

Notes:

(1) Efficiency values are given according to IEC 60034-2-1. They are calculated according to indirect method, with stray load losses determined by measurement.

(2) With effect from 1st January 2015, IE2 motors placed onto the European Market and rated at 7.5kw or above, must be used with a variable speed drive unless their design falls outside of the scope of the European Regulation or their final installation will be outside of the EU / EEA.

(*) Temperature rise ΔT 105 K.

Output		380 V								415 V							
		Rated speed (rpm)	% of full load						Full load current In (A)	Rated speed (rpm)	% of full load						Full load current In (A)
			Efficiency			Power factor					Efficiency			Power factor			
kW	HP	50	75	100	50	75	100	50	75	100	50	75	100	50	75	100	
IV pole - 1500 rpm - 50 Hz																	
0.12	0.16	1360	56.8	58.7	59.1	0.58	0.71	0.80	0.386	1390	53.2	57.1	59.1	0.51	0.64	0.74	0.382
0.18	0.25	1350	60.4	61.3	60.1	0.54	0.67	0.76	0.599	1380	57.7	60.6	61.2	0.50	0.60	0.70	0.585
0.25	0.33	1380	60.0	65.0	68.5	0.53	0.66	0.74	0.749	1410	57.8	64.5	68.5	0.46	0.59	0.69	0.736
0.37	0.5	1360	64.8	66.5	67.4	0.55	0.68	0.78	1.06	1390	61.2	64.9	67.9	0.46	0.60	0.71	1.06
0.55	0.75	1410	73.0	73.1	77.1	0.65	0.77	0.85	1.28	1425	70.7	73.8	77.1	0.56	0.70	0.80	1.24
0.75	1	1400	80.1	79.9	79.8	0.68	0.80	0.84	1.66	1415	77.9	79.2	80.1	0.60	0.73	0.79	1.61
1.1	1.5	1432	81.9	81.8	81.5	0.67	0.78	0.83	2.47	1444	80.1	81.5	82.1	0.58	0.72	0.79	2.36
1.5	2	1430	82.8	83.2	82.8	0.63	0.77	0.83	3.32	1445	80.1	82.3	83.1	0.53	0.68	0.78	3.22
2.2	3	1425	83.5	84.3	84.3	0.65	0.77	0.83	4.80	1440	82.3	84.5	84.9	0.56	0.71	0.79	4.56
3	4	1410	85.6	85.4	85.5	0.67	0.78	0.84	6.35	1425	84.3	85.5	86.0	0.58	0.72	0.80	6.07
4	5.5	1435	86.5	86.6	86.6	0.67	0.78	0.82	8.56	1445	85.3	86.6	87.0	0.58	0.71	0.78	8.20
5.5	7.5	1455	88.1	87.7	87.7	0.73	0.83	0.88	10.8	1460	87.0	87.9	88.3	0.65	0.77	0.84	10.3
7.5	10	1450	89.0	88.7	88.7	0.75	0.83	0.87	14.9	1460	88.3	89.0	89.4	0.67	0.78	0.84	13.9
9.2	12.5	1450	89.6	89.4	89.3	0.74	0.82	0.87	17.8	1455	88.7	89.5	89.8	0.65	0.77	0.84	16.8
11	15	1465	89.5	90.2	89.8	0.69	0.79	0.85	21.9	1470	88.5	90.0	90.3	0.61	0.73	0.81	20.9
15	20	1460	91.0	90.9	90.6	0.70	0.79	0.85	29.6	1470	90.2	90.9	91.2	0.63	0.73	0.81	28.2
18.5	25	1460	91.8	91.7	91.2	0.72	0.81	0.85	36.3	1470	91.1	91.7	91.7	0.50	0.75	0.81	34.7
22	30	1460	92.5	92.4	91.9	0.74	0.83	0.87	41.8	1465	91.8	92.4	92.4	0.66	0.77	0.83	39.9
30	40	1465	92.9	92.9	92.4	0.72	0.81	0.85	58.0	1470	92.3	92.9	92.9	0.65	0.76	0.81	55.5
37	50	1470	93.2	93.1	92.8	0.78	0.86	0.87	69.6	1475	92.7	93.1	93.3	0.70	0.81	0.85	64.9
45	60	1470	93.5	93.6	93.2	0.78	0.86	0.88	83.4	1475	92.9	93.6	93.7	0.70	0.81	0.84	79.5
55	75	1470	93.8	93.8	93.7	0.79	0.86	0.88	101	1475	93.3	93.9	94.1	0.72	0.82	0.86	94.6
75	100	1470	94.3	94.3	94.1	0.78	0.87	0.90	135	1475	93.7	94.2	94.5	0.71	0.82	0.87	127
High-Output Design																	
0.25	0.33	1410	71.0	74.0	73.2	0.65	0.77	0.84	0.618	1425	69.1	73.7	74.4	0.58	0.71	0.79	0.592
0.37	0.5	1410	74.1	75.6	74.8	0.65	0.77	0.84	0.895	1425	71.7	75.1	75.8	0.57	0.70	0.79	0.860
0.55	0.75	1320	70.0	71.0	70.5	0.56	0.69	0.78	1.52	1355	67.0	70.5	70.5	0.46	0.60	0.70	1.55
0.75	1	1415	79.1	79.9	79.6	0.64	0.76	0.83	1.72	1430	76.9	79.6	80.4	0.55	0.69	0.78	1.66
1.1	1.5	1440	80.9	81.5	81.5	0.59	0.71	0.80	2.56	1455	79.2	81.5	82.1	0.51	0.65	0.76	2.45
1.5	2	1415	82.5	82.8	82.8	0.66	0.77	0.83	3.34	1430	81.9	83.2	83.7	0.58	0.71	0.79	3.16
2.2	3	1455	85.0	84.8	84.3	0.67	0.78	0.83	4.78	1465	83.9	84.9	85.4	0.59	0.72	0.79	4.54
4	5.5	1450	87.5	87.1	86.6	0.72	0.83	0.86	8.12	1459	86.4	87.1	87.4	0.65	0.77	0.83	7.63
4	5.5	1450	87.5	87.1	86.6	0.72	0.83	0.86	8.12	1459	86.4	87.1	87.4	0.65	0.77	0.83	7.63
5.5	7.5	1455	88.1	87.7	87.7	0.73	0.83	0.88	10.8	1460	87.0	87.9	88.3	0.65	0.77	0.84	10.3
7.5	10	1450	89.0	88.7	88.7	0.75	0.83	0.87	14.9	1460	88.3	89.0	89.4	0.67	0.78	0.84	13.9
7.5	10	1460	88.5	89.1	88.7	0.69	0.80	0.85	15.1	1470	87.5	89.0	89.1	0.61	0.74	0.81	14.5
9.2	12.5	1460	89.0	89.5	89.3	0.70	0.80	0.85	18.5	1470	88.0	89.4	89.3	0.62	0.74	0.81	17.7
11	15	1450	90.0	89.6	89.8	0.70	0.81	0.86	21.6	1460	89.0	89.5	89.8	0.60	0.74	0.81	21.0
11	15	1465	89.5	90.2	89.8	0.69	0.79	0.85	21.9	1470	88.5	90.0	90.3	0.61	0.73	0.81	20.9
15	20	1460	91.3	91.5	91.0	0.71	0.80	0.85	29.5	1470	90.4	91.4	91.4	0.63	0.74	0.81	28.2
15	20	1460	91.3	91.5	91.0	0.71	0.80	0.85	29.5	1470	90.4	91.4	91.4	0.63	0.74	0.81	28.2
18.5	25	1460	90.5	91.0	91.2	0.71	0.81	0.85	36.3	1470	90.0	91.0	91.2	0.62	0.75	0.81	34.8
18.5	25	1460	91.8	91.7	91.2	0.72	0.81	0.85	36.3	1470	91.1	91.7	91.7	0.50	0.75	0.81	34.7
22	30	1460	92.5	92.4	91.9	0.74	0.83	0.87	41.8	1465	91.8	92.4	92.4	0.66	0.77	0.83	39.9
30	40	1460	91.9	92.3	92.3	0.72	0.81	0.84	58.8	1465	91.5	92.0	92.3	0.64	0.76	0.82	55.1
37	50	1465	93.1	92.9	92.7	0.74	0.83	0.85	71.4	1472	92.5	93.0	93.2	0.67	0.78	0.81	68.2
45	60	1470	92.8	93.0	93.1	0.70	0.80	0.84	87.4	1475	92.4	92.8	93.1	0.61	0.73	0.79	85.1
55	75	1470	93.0	93.5	93.5	0.78	0.85	0.87	103	1475	92.8	93.2	93.6	0.71	0.81	0.85	96.2

Performance Data

W22 Brake Motor - High Efficiency - IE2

Output		Frame	Full load torque (Nm)	Locked rotor current I _L /I _N	Locked rotor torque T _L /T _N	Breakdown torque T _b /T _n	Inertia J (kgm ²)	Allowable locked rotor time (s)		Weight (kg)	Sound dB (A)	400 V								
								Hot	Cold			Rated speed (rpm)	% of full load			Full load current I _N (A)				
													Efficiency				Power factor			
kW	HP												50	75	100	50	75	100		
VI pole - 1000 rpm - 50 Hz																				
0.12	0.16	63	1.27	3.0	1.9	2.0	0.0006	52	114	8.2	43.0	905	42.0	50.0	52.0	0.43	0.53	0.63	0.529	
0.18	0.25	71	1.93	3.2	2.0	2.0	0.0008	96	211	11.0	43.0	890	52.0	58.0	59.0	0.40	0.51	0.61	0.722	
0.25	0.33	71	2.78	3.2	1.9	2.1	0.0008	70	154	13.0	43.0	860	53.0	60.0	61.0	0.37	0.48	0.58	1.02	
0.37	0.5	80	3.88	3.9	1.8	2.0	0.0022	27	59	12.0	43.0	910	63.0	67.0	67.0	0.51	0.66	0.76	1.05	
0.55	0.75	80	5.77	4.1	2.0	2.2	0.0030	21	46	15.5	43.0	910	65.0	71.0	71.0	0.50	0.65	0.75	1.49	
0.75	1	90S	7.75	4.5	2.0	2.1	0.0055	23	51	21.5	45.0	925	74.5	76.0	76.0	0.51	0.64	0.73	1.95	
1.1	1.5	90L	11.4	4.7	2.3	2.2	0.0066	17	37	25.5	45.0	925	76.0	78.1	78.1	0.50	0.63	0.73	2.78	
1.5	2	100L	15.3	5.0	2.0	2.4	0.0110	23	51	32.5	44.0	940	79.5	80.0	80.0	0.51	0.64	0.73	3.71	
2.2	3	112M	21.8	7.1	3.5	3.9	0.0257	17	37	44.0	52.0	965	80.8	82.7	83.5	0.41	0.54	0.64	5.94	
3	4	132S	29.9	5.7	2.0	2.4	0.0359	31	68	66.0	53.0	960	82.5	83.6	83.6	0.50	0.63	0.71	7.30	
4	5.5	132M	39.8	6.0	2.1	2.5	0.0453	21	46	77.0	53.0	960	84.0	84.8	84.8	0.51	0.64	0.72	9.46	
5.5	7.5	132M	54.7	6.4	2.2	2.7	0.0604	19	42	81.0	53.0	960	85.5	86.1	86.1	0.51	0.64	0.72	12.8	
7.5	10	160M	73.9	5.8	2.0	2.6	0.1229	17	37	132	56.0	970	88.3	88.7	88.3	0.64	0.76	0.82	15.0	
9.2	12.5	160L	90.6	6.0	2.2	2.6	0.1492	14	31	146	56.0	970	88.5	88.9	88.6	0.64	0.76	0.82	18.3	
11	15	160L	108	6.0	2.3	2.7	0.1664	13	29	155	56.0	970	89.0	89.5	89.2	0.62	0.74	0.81	22.0	
15	20	180L	148	7.0	2.4	3.0	0.2565	7	15	203	56.0	970	90.3	90.5	90.3	0.70	0.81	0.86	27.9	
18.5	25	200L	181	5.7	2.1	2.5	0.3517	15	33	255	60.0	975	91.0	91.4	91.2	0.67	0.77	0.82	35.7	
22	30	200L	216	6.0	2.2	2.7	0.4037	14	31	266	60.0	975	91.4	91.7	91.5	0.65	0.76	0.82	42.3	
30	40	225S/M	291	6.8	2.1	2.5	0.7192	12	26	404	63.0	985	92.6	92.7	92.6	0.71	0.81	0.86	54.4	
37	50	250S/M	359	6.7	2.2	2.5	1.10	16	35	486	64.0	985	93.0	93.2	93.0	0.73	0.82	0.86	66.8	
45	60	250S/M	437	6.4	2.1	2.3	1.29	15	33	514	64.0	985	93.4	93.5	93.4	0.76	0.84	0.87	79.9	
High-Output Design																				
0.25	0.33	80	2.62	3.9	1.8	2.0	0.0022	27	59	12.0	43.0	910	63.0	67.0	67.0	0.51	0.66	0.76	0.709	
1.5	2	112M	14.9	7.5	3.5	3.9	0.0220	25	55	42.5	52.0	960	80.5	82.5	83.4	0.42	0.54	0.63	4.12	
3	4	132M	29.9	5.7	2.0	2.4	0.0359	31	68	66.0	53.0	960	82.5	83.6	83.6	0.50	0.63	0.71	7.30	
5.5	7.5	160M	54.2	6.0	2.1	2.6	0.1053	19	42	125	56.0	970	87.5	88.0	87.5	0.63	0.75	0.81	11.2	
15	20	180M	148	7.0	2.4	3.0	0.2565	7	15	203	56.0	970	90.3	90.5	90.3	0.70	0.81	0.86	27.9	
37	50	225S/M	359	6.8	2.1	2.5	0.8876	11	24	435	63.0	985	93.0	93.2	93.0	0.72	0.81	0.86	66.8	
VIII pole - 750 rpm - 50 Hz																				
0.18	0.25	80	2.57	3.1	1.9	2.1	0.0024	48	106	13.0	42.0	670	47.0	53.0	55.0	0.44	0.55	0.65	0.727	
0.25	0.33	80	3.57	3.2	1.9	2.1	0.0029	42	92	15.0	42.0	670	49.0	55.0	57.0	0.43	0.55	0.66	0.959	
0.37	0.5	90S	5.12	3.5	1.8	2.0	0.0044	37	81	20.5	43.0	690	56.0	62.0	62.0	0.41	0.52	0.62	1.39	
0.55	0.75	90L	7.67	3.5	1.9	2.0	0.0060	31	68	24.5	43.0	685	61.0	64.0	64.0	0.44	0.56	0.66	1.88	
0.75	1	100L	10.1	4.6	2.0	2.4	0.0110	42	92	32.5	50.0	710	71.0	74.0	74.0	0.40	0.52	0.62	2.36	
1.1	1.5	100L	14.9	4.6	2.1	2.3	0.0127	29	64	34.5	50.0	705	71.0	75.0	75.0	0.40	0.53	0.62	3.41	
1.5	2	112M	20.5	4.7	2.4	2.3	0.0202	29	64	45.0	46.0	700	77.0	79.0	79.0	0.44	0.57	0.67	4.09	
2.2	3	132S	30.0	5.5	2.2	2.4	0.0592	25	55	68.0	48.0	700	81.0	81.5	81.0	0.52	0.65	0.72	5.44	
3	4	132M	41.0	5.5	2.3	2.4	0.0740	19	42	75.0	48.0	700	82.0	82.5	82.0	0.54	0.66	0.73	7.23	
4	5.5	160M	52.7	4.7	2.0	2.2	0.1053	29	64	123	51.0	725	84.0	85.0	85.0	0.52	0.65	0.72	9.43	
5.5	7.5	160M	72.5	4.7	2.0	2.2	0.1404	21	46	139	51.0	725	85.0	86.0	85.5	0.52	0.65	0.73	12.7	
7.5	10	160L	98.8	4.9	2.2	2.3	0.1756	22	48	158	51.0	725	86.0	87.0	87.0	0.52	0.65	0.73	17.0	
9.2	12.5	180M	121	6.0	2.0	2.5	0.2033	11	24	185	51.0	725	88.0	88.0	87.5	0.63	0.75	0.82	18.5	
11	15	180L	145	6.0	2.1	2.4	0.2439	11	24	204	51.0	725	88.0	88.5	88.0	0.65	0.76	0.82	22.0	
15	20	200L	196	4.9	1.9	2.0	0.4220	30	66	267	53.0	730	90.0	90.5	90.0	0.58	0.70	0.76	31.7	
18.5	25	225S/M	241	6.3	2.0	2.4	0.6183	17	37	384	56.0	735	91.5	91.9	91.7	0.65	0.77	0.82	35.5	
22	30	225S/M	286	6.1	2.0	2.4	0.7203	16	35	403	56.0	735	91.7	92.0	92.0	0.67	0.78	0.81	42.6	
30	40	250S/M	390	6.6	2.1	2.7	1.06	13	29	441	56.0	735	92.0	92.4	92.3	0.68	0.79	0.83	56.5	

Notes:

(1) Efficiency values are given according to IEC 60034-2-1. They are calculated according to indirect method, with stray load losses determined by measurement.

(2) With effect from 1st January 2015, IE2 motors placed onto the European Market and rated at 7.5kw or above, must be used with a variable speed drive unless their design falls outside of the scope of the European Regulation or their final installation will be outside of the EU / EEA.

Output		380 V								415 V							
		Rated speed (rpm)	% of full load						Full load current In (A)	Rated speed (rpm)	% of full load						Full load current In (A)
			Efficiency			Power factor					Efficiency			Power factor			
kW	HP	50	75	100	50	75	100	50	75	100	50	75	100	50	75	100	

VI pole - 1000 rpm - 50 Hz

0.12	0.16	895	45.4	52.1	52.9	0.46	0.57	0.67	0.514	910	39.1	47.5	50.7	0.41	0.50	0.59	0.558
0.18	0.25	875	54.2	59.0	58.7	0.43	0.55	0.65	0.717	900	50.1	56.8	58.6	0.38	0.48	0.58	0.737
0.25	0.33	845	56.3	61.9	61.5	0.41	0.52	0.62	0.996	865	50.1	57.8	59.7	0.35	0.45	0.54	1.08
0.37	0.5	895	65.2	67.7	66.0	0.56	0.70	0.80	1.06	915	60.5	65.9	67.1	0.48	0.62	0.73	1.05
0.55	0.75	900	67.5	71.8	70.2	0.55	0.69	0.79	1.51	915	62.5	69.6	70.9	0.47	0.61	0.72	1.50
0.75	1	915	75.8	75.9	75.9	0.55	0.68	0.76	1.98	930	73.2	75.6	76.4	0.48	0.61	0.71	1.92
1.1	1.5	915	77.9	78.5	78.5	0.55	0.67	0.77	2.76	930	74.3	77.3	78.1	0.46	0.59	0.70	2.80
1.5	2	930	80.7	80.1	79.8	0.55	0.69	0.76	3.76	945	78.3	79.7	80.3	0.48	0.61	0.70	3.71
2.2	3	960	82.0	83.1	84.2	0.46	0.60	0.68	5.84	970	79.8	83.2	83.3	0.38	0.50	0.60	6.12
3	4	955	83.4	83.8	83.3	0.54	0.67	0.74	7.39	960	81.4	83.1	83.6	0.46	0.59	0.68	7.34
4	5.5	955	84.9	85.0	84.6	0.55	0.68	0.74	9.74	960	83.0	84.4	84.9	0.47	0.61	0.69	9.50
5.5	7.5	955	86.4	86.3	86.0	0.56	0.68	0.75	13.0	965	84.6	85.7	86.2	0.47	0.61	0.69	12.9
7.5	10	965	88.7	88.6	87.7	0.68	0.79	0.84	15.5	970	87.8	88.6	88.5	0.61	0.73	0.80	14.7
9.2	12.5	965	88.9	88.8	88.1	0.68	0.79	0.84	18.9	970	88.0	88.8	88.8	0.61	0.73	0.80	18.0
11	15	965	89.6	89.5	88.8	0.66	0.77	0.83	22.7	970	88.4	89.3	89.3	0.59	0.71	0.79	21.7
15	20	965	90.6	90.4	89.7	0.74	0.84	0.88	28.9	970	89.9	90.5	90.6	0.67	0.79	0.85	27.1
18.5	25	970	91.5	91.4	90.8	0.71	0.80	0.84	36.9	975	90.5	91.2	91.3	0.63	0.74	0.80	35.2
22	30	970	92.0	91.8	91.2	0.70	0.79	0.84	43.6	975	90.8	91.5	91.6	0.61	0.73	0.80	41.8
30	40	980	92.8	92.5	92.1	0.75	0.83	0.87	56.9	985	92.2	92.6	92.7	0.68	0.79	0.84	53.6
37	50	980	93.2	93.0	92.6	0.77	0.84	0.87	69.8	985	92.7	93.2	93.2	0.70	0.80	0.85	65.0
45	60	980	93.4	93.2	92.8	0.79	0.86	0.88	83.7	985	93.3	93.6	93.7	0.73	0.82	0.86	77.7

High-Output Design

0.25	0.33	895	65.2	67.7	66.0	0.56	0.70	0.80	0.719	915	60.5	65.9	67.1	0.48	0.62	0.73	0.710
1.5	2	945	81.7	82.9	84.0	0.46	0.59	0.68	3.99	965	79.5	82.8	84.1	0.39	0.51	0.60	4.14
3	4	955	83.4	83.8	83.3	0.54	0.67	0.74	7.39	960	81.4	83.1	83.6	0.46	0.59	0.68	7.34
5.5	7.5	965	87.9	87.9	86.9	0.67	0.78	0.83	11.6	970	87.0	87.9	87.8	0.60	0.73	0.79	11.0
15	20	965	90.6	90.4	89.7	0.74	0.84	0.88	28.9	970	89.9	90.5	90.6	0.67	0.79	0.85	27.1
37	50	980	93.1	92.9	92.4	0.76	0.83	0.87	69.9	985	92.8	93.2	93.2	0.69	0.79	0.85	65.0

VIII pole - 750 rpm - 50 Hz

0.18	0.25	660	49.3	54.4	54.9	0.47	0.59	0.69	0.722	675	45.0	51.8	54.5	0.42	0.53	0.62	0.741
0.25	0.33	660	51.1	56.2	56.8	0.47	0.59	0.70	0.955	675	47.0	53.8	56.8	0.42	0.53	0.63	0.972
0.37	0.5	680	59.5	63.8	62.4	0.44	0.56	0.67	1.34	695	53.1	59.9	60.9	0.39	0.49	0.59	1.43
0.55	0.75	675	63.3	65.1	63.5	0.47	0.61	0.70	1.88	690	58.5	62.8	63.9	0.41	0.53	0.63	1.90
0.75	1	705	73.0	75.0	73.9	0.44	0.57	0.65	2.37	715	69.2	73.0	73.7	0.38	0.49	0.59	2.40
1.1	1.5	700	73.6	76.2	74.9	0.45	0.57	0.66	3.38	705	68.8	73.6	74.5	0.37	0.49	0.59	3.48
1.5	2	695	78.8	79.6	78.5	0.49	0.61	0.70	4.15	705	75.3	78.2	78.9	0.41	0.53	0.63	4.20
2.2	3	695	81.8	81.5	79.9	0.57	0.69	0.75	5.58	705	80.1	81.4	81.4	0.49	0.62	0.70	5.37
3	4	690	82.7	82.4	80.8	0.58	0.70	0.75	7.52	705	81.1	82.4	82.5	0.50	0.63	0.71	7.13
4	5.5	720	84.8	85.0	84.4	0.56	0.68	0.74	9.73	730	83.2	84.7	85.2	0.49	0.62	0.70	9.33
5.5	7.5	720	85.8	86.0	84.9	0.56	0.68	0.75	13.1	725	84.2	85.7	85.7	0.49	0.62	0.71	12.6
7.5	10	720	86.8	87.2	86.6	0.56	0.69	0.76	17.3	725	85.1	86.7	87.1	0.49	0.62	0.71	16.9
9.2	12.5	720	88.5	87.9	86.8	0.67	0.78	0.84	19.2	725	87.4	87.9	87.8	0.59	0.72	0.80	18.2
11	15	720	88.4	88.3	87.2	0.70	0.79	0.84	22.8	725	87.5	88.5	88.4	0.64	0.75	0.81	21.4
15	20	725	90.5	90.4	89.4	0.62	0.73	0.78	32.7	730	89.4	90.4	90.2	0.55	0.67	0.74	31.3
18.5	25	730	91.8	91.8	91.2	0.69	0.80	0.84	36.7	735	91.1	91.9	91.9	0.62	0.74	0.80	35.0
22	30	730	91.9	91.8	91.4	0.70	0.81	0.83	44.1	735	91.4	92.0	92.2	0.64	0.76	0.80	41.5
30	40	730	92.3	92.3	91.8	0.73	0.82	0.85	58.4	735	91.6	92.3	92.5	0.64	0.76	0.81	55.7

Performance Data

W22 Brake Motor - Premium Efficiency - IE3

Output		Frame	Full load torque (Nm)	Locked rotor current I/In	Locked rotor torque TI/Tn	Breakdown torque Tb/Tn	Inertia J (kgm ²)	Allowable locked rotor time (s)		Weight (kg)	Sound dB (A)	400 V								
								Rated speed (rpm)	% of full load						Full load current In (A)					
									Efficiency			Power factor								
kW	HP							Hot	Cold			50	75	100	50	75	100			
II pole - 3000 rpm - 50 Hz																				
0.12	0.16	63	0.410	5.4	3.1	3.3	0.0001	30	66	7.2	52.0	2820	58.0	60.8	60.8	0.54	0.67	0.76	0.375	
0.18	0.25	63	0.610	5.2	3.0	3.2	0.0002	22	48	7.7	52.0	2815	61.0	65.9	65.9	0.53	0.65	0.74	0.533	
0.25	0.33	63	0.850	5.5	3.2	3.2	0.0002	17	37	8.2	52.0	2805	63.0	68.0	69.7	0.54	0.68	0.77	0.672	
0.37	0.5	71	1.25	6.0	2.5	2.5	0.0004	12	26	9.0	56.0	2820	73.0	73.8	73.8	0.66	0.79	0.85	0.851	
0.55	0.75	71	1.90	5.9	3.0	3.0	0.0005	18	40	10.0	56.0	2770	75.0	76.0	77.8	0.68	0.81	0.86	1.19	
0.75	1	80	2.54	7.5	3.5	3.5	0.0008	25	55	15.0	59.0	2825	80.0	82.0	81.0	0.63	0.76	0.82	1.63	
1.1	1.5	80	3.71	7.4	3.6	3.6	0.0009	23	51	16.5	59.0	2830	81.0	83.5	83.0	0.63	0.76	0.82	2.33	
1.5	2	90S	4.99	7.6	3.3	3.3	0.0020	15	33	20.0	62.0	2875	83.0	85.0	84.5	0.64	0.76	0.83	3.09	
2.2	3	90L	7.32	7.5	3.4	3.5	0.0026	12	26	26.0	62.0	2870	86.0	86.5	86.3	0.65	0.77	0.83	4.43	
3	4	100L	9.85	8.5	3.4	3.4	0.0064	15	33	39.0	67.0	2910	85.5	87.3	87.3	0.69	0.81	0.86	5.77	
4	5.5	112M	13.2	7.7	2.9	3.5	0.0081	22	48	47.0	64.0	2900	88.0	88.4	88.4	0.69	0.80	0.86	7.59	
5.5	7.5	132S	17.9	7.9	2.4	3.5	0.0180	16	35	71.0	67.0	2930	86.9	88.7	89.4	0.66	0.78	0.84	10.6	
7.5	10	132S	24.5	8.8	2.7	3.6	0.0234	10	22	74.0	67.0	2930	88.5	89.8	90.3	0.68	0.80	0.85	14.1	
9.2	12.5	132M	30.0	8.5	2.9	3.3	0.0303	16	35	87.0	67.0	2930	90.4	91.1	90.7	0.75	0.84	0.88	16.6	
11	15	160M	35.7	8.0	2.6	3.4	0.0482	12	26	131	67.0	2945	90.3	91.4	91.4	0.71	0.82	0.87	20.0	
15	20	160M	48.7	8.3	2.8	3.5	0.0551	8	18	131	67.0	2945	90.9	91.8	92.1	0.67	0.79	0.85	27.7	
18.5	25	160L	60.0	8.6	3.1	3.7	0.0663	6	13	189	67.0	2945	91.5	92.3	92.6	0.69	0.80	0.85	33.9	
22	30	180M	71.3	8.3	2.7	3.6	0.0968	6	13	194	67.0	2950	92.3	93.0	92.9	0.69	0.80	0.86	39.7	
30	40	200L	96.8	7.7	3.0	3.0	0.1703	16	35	266	72.0	2960	92.2	93.2	93.5	0.69	0.80	0.85	54.5	
37	50	200L	119	7.7	3.1	3.0	0.1881	13	29	291	72.0	2960	92.6	93.4	93.8	0.69	0.79	0.84	67.8	
High-Output Design																				
0.75	1	90S	2.47	8.2	3.3	3.4	0.0015	24	53	19.5	62.0	2900	79.0	82.5	81.5	0.63	0.75	0.82	1.62	
1.1	1.5	90S	3.65	7.8	3.3	3.3	0.0018	19	42	20.0	62.0	2880	82.0	84.2	83.5	0.63	0.75	0.82	2.32	
2.2	3	100L	7.22	8.5	3.2	3.3	0.0059	22	48	35.0	67.0	2910	85.0	86.6	86.6	0.71	0.82	0.87	4.21	
4	5.5	132S	13.0	7.9	2.5	3.1	0.0180	24	53	70.0	67.0	2945	86.9	88.7	88.6	0.73	0.82	0.87	7.49	
5.5	7.5	132M	17.9	7.9	2.4	3.5	0.0180	16	35	71.0	67.0	2930	86.9	88.7	89.4	0.66	0.78	0.84	10.6	
7.5	10	132M	24.5	8.8	2.7	3.6	0.0234	10	22	74.0	67.0	2930	88.5	89.8	90.3	0.68	0.80	0.85	14.1	
11	15	132M	35.9	8.2	2.7	3.0	0.0303	11	24	89.0	67.0	2925	90.6	91.1	91.2	0.75	0.85	0.89	19.6	
11	15	160L	35.7	8.0	2.6	3.4	0.0482	12	26	124	67.0	2945	90.3	91.4	91.4	0.71	0.82	0.87	20.0	
15	20	160L	48.7	8.3	2.8	3.5	0.0551	8	18	131	67.0	2945	90.9	91.8	92.1	0.67	0.79	0.85	27.7	
18.5	25	180M	60.0	7.6	2.3	3.1	0.0973	11	24	194	67.0	2945	91.5	92.0	92.6	0.77	0.85	0.88	32.8	
22	30	180L	71.3	8.3	2.7	3.6	0.0968	6	13	194	67.0	2950	92.3	93.0	92.9	0.69	0.80	0.86	39.7	

Note:
 (1) Efficiency values are given according to IEC 60034-2-1. They are calculated according to indirect method, with stray load losses determined by measurement.

Output		380 V									415 V								
		Rated speed (rpm)	% of full load						Full load current In (A)	Rated speed (rpm)	% of full load						Full load current In (A)		
			Efficiency			Power factor					Efficiency			Power factor					
kW	HP	50	75	100	50	75	100	50	75	100	50	75	100	50	75	100			
II pole - 3000 rpm - 50 Hz																			
0.12	0.16	2795	59.0	60.8	60.8	0.58	0.71	0.79	0.380	2835	57.0	60.8	60.8	0.51	0.64	0.73	0.376		
0.18	0.25	2790	62.6	65.9	65.9	0.57	0.70	0.79	0.525	2825	59.6	65.2	65.9	0.49	0.62	0.71	0.535		
0.25	0.33	2780	64.6	68.7	69.7	0.59	0.73	0.81	0.673	2820	61.5	67.2	69.7	0.51	0.64	0.74	0.674		
0.37	0.5	2795	73.6	74.3	73.8	0.71	0.82	0.87	0.876	2825	72.4	73.8	73.8	0.63	0.76	0.83	0.840		
0.55	0.75	2740	75.6	75.7	77.8	0.73	0.84	0.88	1.22	2790	74.4	76.0	77.8	0.65	0.78	0.84	1.17		
0.75	1	2805	80.0	80.5	80.7	0.68	0.80	0.85	1.66	2835	79.1	81.0	81.1	0.59	0.72	0.79	1.63		
1.1	1.5	2810	82.0	83.7	83.1	0.69	0.80	0.85	2.37	2840	80.0	83.0	83.4	0.58	0.72	0.79	2.32		
1.5	2	2860	83.7	85.0	84.4	0.69	0.80	0.85	3.18	2885	82.2	84.8	85.2	0.59	0.72	0.80	3.06		
2.2	3	2855	86.5	86.4	85.9	0.70	0.81	0.86	4.52	2880	85.3	86.4	86.5	0.61	0.74	0.81	4.37		
3	4	2900	86.0	87.4	87.1	0.75	0.84	0.88	5.95	2915	85.0	87.2	87.4	0.66	0.78	0.84	5.68		
4	5.5	2890	88.0	88.2	88.2	0.73	0.83	0.88	7.83	2905	87.5	88.0	88.4	0.65	0.77	0.84	7.49		
5.5	7.5	2925	87.6	88.9	89.2	0.71	0.82	0.87	10.8	2935	86.1	88.3	89.2	0.61	0.74	0.81	10.6		
7.5	10	2926	89.2	90.1	90.1	0.73	0.83	0.88	14.4	2940	87.9	89.7	90.3	0.63	0.76	0.83	13.9		
9.2	12.5	2920	90.7	91.0	90.8	0.79	0.87	0.90	17.1	2935	90.1	91.0	91.3	0.71	0.82	0.87	16.1		
11	15	2940	90.7	91.2	91.2	0.75	0.84	0.88	20.8	2950	89.9	91.3	91.4	0.68	0.79	0.85	19.7		
15	20	2940	91.0	91.6	91.9	0.72	0.82	0.87	28.5	2950	90.3	91.6	91.9	0.63	0.76	0.82	27.7		
18.5	25	2945	92.0	92.3	92.4	0.74	0.83	0.88	34.6	2950	91.0	92.2	92.4	0.64	0.77	0.83	33.6		
22	30	2945	92.4	92.7	92.7	0.74	0.83	0.87	41.4	2955	92.0	92.8	92.7	0.66	0.78	0.84	39.3		
30	40	2960	92.6	93.2	93.3	0.75	0.83	0.87	56.2	2965	91.8	93.0	93.3	0.64	0.76	0.82	54.6		
37	50	2960	93.0	93.6	93.7	0.75	0.84	0.87	69.0	2965	92.0	93.2	93.7	0.63	0.76	0.82	67.0		
High-Output Design																			
0.75	1	2885	79.5	82.5	81.0	0.68	0.78	0.84	1.67	2910	78.4	82.3	81.5	0.60	0.72	0.79	1.62		
1.1	1.5	2865	82.6	84.2	84.0	0.68	0.79	0.84	2.37	2890	81.4	84.0	84.7	0.59	0.72	0.80	2.26		
2.2	3	2900	85.4	86.5	86.5	0.75	0.84	0.89	4.36	2915	84.7	86.5	86.8	0.68	0.80	0.86	4.10		
4	5.5	2935	87.1	88.6	88.7	0.76	0.85	0.89	7.70	2950	86.6	88.6	89.2	0.69	0.80	0.86	7.25		
5.5	7.5	2925	87.6	88.9	89.2	0.71	0.82	0.87	10.8	2935	86.1	88.3	89.2	0.61	0.74	0.81	10.6		
7.5	10	2926	89.2	90.1	90.1	0.73	0.83	0.88	14.4	2940	87.9	89.7	90.3	0.63	0.76	0.83	13.9		
11	15	2915	90.9	91.0	91.2	0.80	0.87	0.90	20.4	2930	90.2	91.1	91.4	0.72	0.82	0.87	19.2		
11	15	2940	90.7	91.2	91.2	0.75	0.84	0.88	20.8	2950	89.9	91.3	91.4	0.68	0.79	0.85	19.7		
15	20	2940	91.0	91.6	91.9	0.72	0.82	0.87	28.5	2950	90.3	91.6	91.9	0.63	0.76	0.82	27.7		
18.5	25	2940	92.7	92.6	92.4	0.80	0.87	0.90	33.8	2950	92.5	92.9	92.5	0.75	0.84	0.88	31.6		
22	30	2945	92.4	92.7	92.7	0.74	0.83	0.87	41.4	2955	92.0	92.8	92.7	0.66	0.78	0.84	39.3		



Performance Data

W22 Brake Motor - Premium Efficiency - IE3

Output		Frame	Full load torque (Nm)	Locked rotor current I _L /I _n	Locked rotor torque T _L /T _n	Breakdown torque T _b /T _n	Inertia J (kgm ²)	Allowable locked rotor time (s)		Weight (kg)	Sound dB (A)	Rated speed (rpm)	400 V						Full load current I _n (A)
								Hot	Cold				% of full load			Power factor			
													Efficiency			Power factor			
kW	HP											50	75	100	50	75	100		
IV pole - 1500 rpm - 50 Hz																			
0.12	0.16	63	0.840	4.4	2.1	2.3	0.0004	30	66	6.2	44.0	1370	57.0	63.0	64.8	0.52	0.62	0.73	0.366
0.18	0.25	63	1.26	4.7	2.1	2.4	0.0006	30	66	8.2	44.0	1370	65.0	67.0	69.9	0.53	0.63	0.72	0.516
0.25	0.33	71	1.72	4.8	2.3	2.3	0.0009	30	66	9.5	43.0	1390	69.0	72.0	73.5	0.52	0.65	0.72	0.682
0.37	0.5	71	2.55	4.8	2.8	2.9	0.0008	30	66	11.0	43.0	1385	73.0	75.0	77.3	0.50	0.62	0.70	0.987
0.55	0.75	80	3.70	6.6	2.9	3.2	0.0027	20	44	14.0	44.0	1420	77.0	79.0	80.8	0.61	0.74	0.80	1.23
0.75	1	80	5.05	6.7	3.0	3.3	0.0032	18	40	16.0	44.0	1420	80.0	82.0	82.5	0.59	0.72	0.81	1.62
1.1	1.5	90S	7.22	7.6	2.5	3.3	0.0055	15	33	22.0	49.0	1455	83.0	84.5	84.5	0.59	0.72	0.80	2.35
1.5	2	90L	9.88	7.4	2.6	3.4	0.0066	13	29	25.5	49.0	1450	84.0	86.0	85.5	0.58	0.72	0.80	3.17
2.2	3	100L	14.7	7.4	3.2	3.5	0.0090	18	40	35.5	53.0	1435	86.5	87.0	87.0	0.60	0.73	0.80	4.56
3	4	112M	19.7	7.1	2.3	3.0	0.0169	25	55	49.0	56.0	1455	87.0	88.0	88.0	0.62	0.74	0.81	6.07
4	5.5	112M	26.4	7.0	2.3	3.1	0.0180	15	33	50.0	56.0	1450	88.7	89.1	88.8	0.62	0.74	0.81	8.03
5.5	7.5	132S	36.0	8.3	2.1	3.3	0.0491	12	26	75.0	56.0	1460	89.0	89.6	89.7	0.69	0.80	0.85	10.4
7.5	10	132M	49.1	8.3	2.4	3.5	0.0563	7	15	83.0	56.0	1460	90.5	90.8	90.6	0.69	0.80	0.86	13.9
9.2	12.5	132M/L	60.0	8.6	2.8	3.5	0.0698	10	22	91.0	56.0	1465	90.3	91.0	91.0	0.64	0.76	0.82	17.4
11	15	160M	71.5	7.5	2.8	3.2	0.1191	11	24	132	61.0	1470	91.1	91.8	91.6	0.65	0.77	0.83	20.9
15	20	160L	97.8	7.2	2.8	3.1	0.1534	8	18	154	61.0	1465	92.2	92.5	92.3	0.67	0.78	0.84	27.9
18.5	25	180M	120	7.4	3.0	3.2	0.1740	13	29	197	61.0	1470	92.2	92.8	92.8	0.64	0.76	0.82	35.1
22	30	180L	143	7.3	3.4	3.4	0.2097	11	24	214	61.0	1470	92.3	93.0	93.2	0.66	0.77	0.83	41.0
30	40	200L	194	7.5	2.8	3.1	0.3202	12	26	269	63.0	1480	92.9	93.6	93.7	0.63	0.75	0.81	57.1
37	50	200L	239	7.0	2.6	3.0	0.3994	14	31	325	63.0	1480	93.3	94.0	94.5	0.64	0.76	0.82	68.9
High-Output Design																			
0.75	1	90S	4.93	7.8	2.4	3.3	0.0049	21	46	21.0	49.0	1455	82.5	84.0	84.5	0.60	0.73	0.80	1.60
1.1	1.5	90L	7.22	7.6	2.5	3.3	0.0055	15	33	22.0	49.0	1455	83.0	84.5	84.5	0.59	0.72	0.80	2.35
1.5	2	100L	9.95	7.7	3.1	3.4	0.0082	25	55	34.0	53.0	1440	85.5	86.0	86.0	0.61	0.73	0.80	3.15
2.2	3	112M	14.5	6.8	2.0	3.0	0.0143	31	68	47.0	56.0	1450	87.5	88.2	88.2	0.62	0.74	0.81	4.44
5.5	7.5	132M	36.0	8.3	2.1	3.3	0.0491	12	26	75.0	56.0	1460	89.0	89.6	89.7	0.69	0.80	0.85	10.4
9.2	12.5	160M	59.6	7.2	2.5	3.0	0.1118	16	35	128	61.0	1475	90.0	91.4	91.3	0.66	0.77	0.83	17.5
11	15	160L	71.5	7.5	2.8	3.2	0.1191	11	24	132	61.0	1470	91.1	91.8	91.6	0.65	0.77	0.83	20.9
15	20	180M	97.5	7.0	2.5	3.0	0.0000	23	51	184	61.0	1470	91.9	92.5	92.3	0.66	0.77	0.83	28.3
18.5	25	180L	120	7.4	3.0	3.2	0.1740	13	29	197	61.0	1470	92.2	92.8	92.8	0.64	0.76	0.82	35.1

Note:
 (1) Efficiency values are given according to IEC 60034-2-1. They are calculated according to indirect method, with stray load losses determined by measurement.

Output		380 V									415 V								
		Rated speed (rpm)	% of full load						Full load current In (A)	Rated speed (rpm)	% of full load						Full load current In (A)		
			Efficiency			Power factor					Efficiency			Power factor					
kW	HP		50	75	100	50	75	100		50	75	100	50	75	100				
IV pole - 1500 rpm - 50 Hz																			
0.12	0.16	1355	58.6	64.0	64.8	0.56	0.69	0.76	0.370	1380	55.6	63.0	64.8	0.50	0.62	0.72	0.358		
0.18	0.25	1355	65.0	67.0	69.9	0.57	0.67	0.75	0.522	1380	65.0	67.0	69.9	0.50	0.61	0.70	0.512		
0.25	0.33	1375	67.0	69.1	73.5	0.56	0.69	0.75	0.689	1400	65.1	68.6	73.4	0.50	0.62	0.69	0.687		
0.37	0.5	1370	73.0	75.0	77.3	0.53	0.64	0.72	1.01	1395	73.0	75.0	77.3	0.47	0.59	0.68	0.979		
0.55	0.75	1410	78.0	79.1	80.8	0.65	0.77	0.83	1.25	1430	76.0	78.9	80.8	0.57	0.71	0.77	1.23		
0.75	1	1410	80.8	82.0	82.5	0.64	0.75	0.83	1.66	1425	79.1	81.8	82.8	0.56	0.69	0.79	1.60		
1.1	1.5	1450	84.0	84.7	84.3	0.64	0.76	0.83	2.39	1460	82.0	84.1	84.8	0.55	0.69	0.77	2.34		
1.5	2	1445	85.0	86.2	85.6	0.63	0.76	0.83	3.21	1455	83.1	85.7	86.1	0.54	0.68	0.77	3.15		
2.2	3	1430	87.2	87.1	86.7	0.65	0.77	0.83	4.64	1440	85.7	86.8	87.2	0.57	0.70	0.78	4.50		
3	4	1450	87.5	87.7	87.7	0.66	0.77	0.83	6.26	1460	86.5	88.0	88.1	0.59	0.71	0.79	6.00		
4	5.5	1445	89.3	89.0	88.6	0.67	0.78	0.83	8.26	1455	88.2	88.9	89.3	0.59	0.72	0.79	7.89		
5.5	7.5	1460	89.0	89.6	89.6	0.73	0.83	0.87	10.7	1465	89.4	89.6	89.8	0.65	0.78	0.84	10.1		
7.5	10	1460	90.0	90.2	90.4	0.71	0.82	0.87	14.5	1465	89.2	90.3	90.4	0.62	0.75	0.83	13.9		
9.2	12.5	1460	91.0	91.1	91.0	0.69	0.80	0.85	17.7	1470	89.5	90.6	91.0	0.60	0.73	0.80	17.2		
11	15	1470	91.7	91.4	91.4	0.69	0.80	0.85	21.5	1475	90.6	91.4	91.5	0.61	0.74	0.81	20.6		
15	20	1465	92.4	92.4	92.1	0.70	0.80	0.85	29.1	1470	91.6	92.3	92.1	0.62	0.75	0.81	28.0		
18.5	25	1470	92.7	92.6	92.6	0.69	0.79	0.84	36.1	1475	91.8	92.6	92.6	0.61	0.73	0.80	34.7		
22	30	1470	92.5	92.8	93.0	0.70	0.81	0.85	42.3	1475	91.9	92.8	93.0	0.62	0.74	0.81	40.6		
30	40	1475	93.4	93.6	93.6	0.68	0.79	0.84	58.0	1480	92.3	93.3	93.6	0.59	0.72	0.79	56.4		
37	50	1480	93.7	94.1	94.4	0.69	0.79	0.84	70.9	1480	92.9	93.8	94.5	0.60	0.73	0.80	68.1		
High-Output Design																			
0.75	1	1450	83.2	84.1	84.0	0.64	0.76	0.83	1.63	1460	81.8	83.8	84.6	0.56	0.70	0.78	1.58		
1.1	1.5	1450	84.0	84.7	84.3	0.64	0.76	0.83	2.39	1460	82.0	84.1	84.8	0.55	0.69	0.77	2.34		
1.5	2	1430	85.5	86.0	86.0	0.65	0.77	0.83	3.19	1445	85.5	86.0	86.0	0.58	0.71	0.78	3.11		
2.2	3	1445	87.9	88.1	87.6	0.66	0.77	0.83	4.60	1455	87.2	88.2	88.5	0.59	0.72	0.79	4.38		
5.5	7.5	1460	89.0	89.6	89.6	0.73	0.83	0.87	10.7	1465	89.4	89.6	89.8	0.65	0.78	0.84	10.1		
9.2	12.5	1470	92.2	92.3	91.4	0.70	0.81	0.85	18.0	1475	91.6	92.3	92.0	0.64	0.76	0.82	17.0		
11	15	1470	91.7	91.4	91.4	0.69	0.80	0.85	21.5	1475	90.6	91.4	91.5	0.61	0.74	0.81	20.6		
15	20	1470	92.6	92.9	92.3	0.70	0.80	0.85	29.0	1475	92.0	92.8	92.6	0.63	0.75	0.81	27.8		
18.5	25	1470	92.7	92.6	92.6	0.69	0.79	0.84	36.1	1475	91.8	92.6	92.6	0.61	0.73	0.80	34.7		



Performance Data

W22 Brake Motor - Premium Efficiency - IE3

Output		Frame	Full load torque (Nm)	Locked rotor current I _L /I _n	Locked rotor torque T _L /T _n	Breakdown torque T _b /T _n	Inertia J (kgm ²)	Allowable locked rotor time (s)		Weight (kg)	Sound dB (A)	400 V								
								Rated speed (rpm)	% of full load						Full load current I _n (A)					
									Efficiency			Power factor								
kW	HP							Hot	Cold			50	75	100	50	75	100			
VI pole - 1000 rpm - 50 Hz																				
0.12	0.16	63	1.27	3.1	1.8	2.1	0.0007	30	66	8.7	43.0	905	50.0	55.0	57.7	0.44	0.53	0.62	0.484	
0.18	0.25	71	1.91	3.2	2.0	2.1	0.0009	30	66	13.0	43.0	900	56.0	62.0	63.9	0.38	0.48	0.57	0.713	
0.25	0.33	80	2.50	4.3	1.7	2.4	0.0000	25	55	13.5	43.0	955	63.6	68.5	68.8	0.47	0.60	0.71	0.739	
0.37	0.5	80	3.82	4.5	1.9	2.1	0.0025	25	55	14.0	43.0	925	66.0	69.5	73.5	0.51	0.65	0.75	0.969	
0.55	0.75	90S	5.47	5.5	2.3	2.8	0.0055	35	77	21.5	45.0	960	77.0	77.2	77.5	0.48	0.62	0.71	1.44	
0.75	1	90L	7.62	5.2	2.5	2.8	0.0060	31	68	24.5	45.0	940	76.5	79.0	79.0	0.49	0.62	0.71	1.93	
1.1	1.5	100L	11.1	4.9	2.0	2.4	0.0110	32	70	32.5	44.0	945	80.5	81.0	81.0	0.51	0.65	0.73	2.69	
1.5	2	100L	15.1	5.5	2.3	2.8	0.0143	31	68	36.0	44.0	950	81.5	82.5	82.5	0.49	0.62	0.71	3.70	
2.2	3	112M	22.1	6.0	2.5	2.6	0.0257	26	57	52.0	52.0	950	83.0	84.5	84.5	0.53	0.64	0.72	5.22	
3	4	132S	29.7	5.8	1.8	2.6	0.0416	40	88	74.0	53.0	965	85.0	85.6	85.8	0.53	0.66	0.73	6.91	
4	5.5	132M	39.6	6.1	1.9	2.7	0.0492	25	55	79.0	53.0	965	86.0	86.8	86.8	0.53	0.66	0.73	9.11	
5.5	7.5	132M/L	54.5	7.0	2.5	2.8	0.0755	26	57	87.0	53.0	965	86.5	88.0	88.0	0.50	0.64	0.70	12.9	
7.5	10	160M	73.5	6.3	2.2	2.7	0.1404	16	35	137	56.0	975	88.5	89.3	89.3	0.64	0.76	0.82	14.8	
9.2	12.5	160L	90.2	6.5	2.3	2.9	0.1756	18	40	154	56.0	975	90.0	90.6	90.0	0.64	0.75	0.81	18.2	
11	15	160L	108	7.1	2.8	3.2	0.1931	12	26	159	56.0	975	89.0	90.1	90.5	0.60	0.73	0.80	21.9	
15	20	180L	147	7.7	2.6	3.2	0.2970	8	18	214	56.0	975	91.5	91.5	91.4	0.68	0.79	0.84	28.2	
18.5	25	200L	180	6.3	2.4	2.8	0.3510	16	35	256	60.0	980	91.0	91.7	91.9	0.63	0.75	0.81	35.9	
22	30	200L	215	6.4	2.4	2.8	0.4212	15	33	266	60.0	980	91.4	92.0	92.4	0.64	0.76	0.81	42.4	
High-Output Design																				
1.1	1.5	112M	11.0	6.2	2.3	2.8	0.0220	28	62	45.0	52.0	960	80.0	81.0	82.0	0.52	0.64	0.70	2.77	
1.5	2	112M	14.9	6.0	2.1	2.8	0.0202	28	62	48.0	52.0	960	84.5	85.5	85.5	0.51	0.63	0.71	3.57	
2.2	3	132S	21.7	5.7	1.8	2.7	0.0492	30	66	72.0	53.0	970	86.0	87.5	87.5	0.52	0.64	0.72	5.04	
VIII pole - 750 rpm - 50 Hz																				
0.12	0.16	71	1.76	2.4	1.8	2.0	0.0009	30	66	13.0	41.0	650	44.0	50.0	52.5	0.35	0.43	0.50	0.660	
0.18	0.25	80	2.53	3.3	2.0	2.2	0.0029	30	66	15.0	42.0	680	51.0	57.0	58.7	0.45	0.55	0.65	0.681	
0.25	0.33	80	3.49	3.5	2.0	2.2	0.0034	30	66	16.0	42.0	685	53.0	60.0	64.1	0.42	0.52	0.63	0.894	
0.37	0.5	90S	5.12	3.7	2.0	2.3	0.0055	30	66	21.5	43.0	690	61.0	66.0	69.3	0.41	0.53	0.62	1.24	
0.55	0.75	90L	7.62	3.8	1.9	2.2	0.0066	29	64	25.5	43.0	690	65.0	70.0	73.0	0.44	0.57	0.67	1.62	
0.75	1	100L	10.1	4.6	1.9	2.3	0.0127	30	66	34.5	50.0	710	72.5	75.5	75.5	0.41	0.53	0.62	2.31	
1.1	1.5	100L	14.8	4.6	2.1	2.4	0.0143	30	66	37.0	50.0	710	73.0	76.0	77.7	0.41	0.53	0.62	3.30	
1.5	2	112M	20.3	5.0	2.5	2.8	0.0238	28	62	49.0	46.0	705	79.0	79.5	79.9	0.45	0.59	0.68	3.98	
2.2	3	132S	29.6	6.2	2.3	2.5	0.0690	27	59	78.0	48.0	710	81.5	82.0	82.1	0.51	0.65	0.72	5.37	
3	4	132M	40.4	6.4	2.4	2.6	0.0838	21	46	84.0	48.0	710	82.5	83.5	83.5	0.51	0.64	0.72	7.20	
4	5.5	160M	52.7	5.0	2.1	2.3	0.1229	34	75	133	51.0	725	85.0	86.0	86.0	0.52	0.65	0.72	9.32	
5.5	7.5	160M	72.5	5.0	2.1	2.3	0.1492	28	62	142	51.0	725	86.0	87.3	87.3	0.52	0.65	0.73	12.5	
7.5	10	160L	98.2	5.3	2.2	2.5	0.2199	22	48	164	51.0	730	87.0	88.3	88.5	0.52	0.65	0.73	16.8	
9.2	12.5	180M	121	6.0	2.0	2.6	0.2575	15	33	202	51.0	725	89.0	89.3	89.6	0.63	0.75	0.82	18.1	
11	15	180L	145	6.5	2.3	2.7	0.2846	12	26	214	51.0	725	89.5	90.0	90.0	0.55	0.68	0.76	23.2	
15	20	200L	196	4.8	1.9	2.1	0.4571	34	75	261	56.0	730	89.0	89.6	89.8	0.56	0.68	0.74	32.6	

Note:
 (1) Efficiency values are given according to IEC 60034-2-1. They are calculated according to indirect method, with stray load losses determined by measurement.

Output		380 V									415 V						
		Rated speed (rpm)	% of full load						Full load current In (A)	Rated speed (rpm)	% of full load						Full load current In (A)
			Efficiency			Power factor					Efficiency			Power factor			
kW	HP	50	75	100	50	75	100	50	75	100	50	75	100	50	75	100	
VI pole - 1000 rpm - 50 Hz																	
0.12	0.16	890	48.7	54.7	57.7	0.47	0.56	0.66	0.479	910	50.0	55.0	57.7	0.42	0.50	0.59	0.490
0.18	0.25	885	57.7	62.8	63.9	0.43	0.55	0.64	0.669	910	54.5	61.2	63.9	0.38	0.48	0.57	0.688
0.25	0.33	950	65.9	68.0	68.6	0.51	0.64	0.74	0.748	960	61.7	68.2	68.8	0.45	0.57	0.68	0.743
0.37	0.5	915	67.6	69.9	73.5	0.55	0.69	0.79	0.968	930	64.3	68.8	73.5	0.48	0.62	0.72	0.973
0.55	0.75	950	76.0	77.0	77.2	0.52	0.66	0.74	1.46	960	77.2	77.5	77.6	0.45	0.59	0.68	1.45
0.75	1	930	77.5	79.2	78.9	0.53	0.66	0.74	1.95	945	75.3	78.6	79.1	0.46	0.59	0.69	1.91
1.1	1.5	940	81.2	80.9	81.0	0.55	0.68	0.75	2.75	950	79.9	80.9	81.5	0.48	0.62	0.70	2.68
1.5	2	945	82.3	82.6	82.5	0.53	0.66	0.74	3.73	955	80.6	82.3	82.8	0.46	0.59	0.68	3.71
2.2	3	945	83.6	84.4	84.3	0.57	0.68	0.75	5.29	955	82.3	84.3	84.7	0.50	0.62	0.70	5.16
3	4	960	85.0	85.8	85.8	0.57	0.69	0.76	6.99	970	85.2	85.8	86.0	0.49	0.63	0.71	6.84
4	5.5	960	86.3	86.8	86.8	0.57	0.70	0.76	9.21	970	85.4	86.5	86.8	0.49	0.62	0.71	9.03
5.5	7.5	960	87.4	88.3	88.0	0.55	0.68	0.75	12.7	965	85.8	87.7	88.0	0.47	0.61	0.69	12.6
7.5	10	970	88.9	89.0	89.1	0.68	0.79	0.84	15.2	980	88.0	89.0	89.1	0.61	0.73	0.80	14.6
9.2	12.5	970	89.5	90.0	90.0	0.68	0.78	0.83	18.7	975	89.6	90.0	90.0	0.61	0.73	0.79	18.0
11	15	975	89.7	90.3	90.3	0.65	0.77	0.83	22.3	980	88.3	89.8	90.3	0.57	0.70	0.78	21.7
15	20	975	90.7	91.0	91.2	0.72	0.81	0.86	29.1	980	91.3	91.6	91.2	0.65	0.77	0.84	27.3
18.5	25	980	91.0	91.7	91.7	0.68	0.78	0.83	36.9	985	90.3	91.4	91.7	0.59	0.72	0.78	36.0
22	30	980	92.0	92.2	92.2	0.69	0.79	0.84	43.2	980	90.8	91.8	92.2	0.60	0.72	0.79	42.0
High-Output Design																	
1.1	1.5	955	80.0	81.0	82.0	0.55	0.70	0.72	2.83	960	80.0	81.0	82.0	0.48	0.62	0.68	2.74
1.5	2	955	85.1	85.4	84.9	0.54	0.66	0.74	3.63	960	84.0	85.4	85.8	0.48	0.60	0.69	3.52
2.2	3	965	86.5	87.5	87.1	0.55	0.67	0.74	5.19	973	85.6	87.4	87.7	0.48	0.61	0.70	4.99

VIII pole - 750 rpm - 50 Hz																	
0.12	0.16	635	46.6	51.7	52.9	0.38	0.46	0.54	0.638	655	41.8	48.2	51.4	0.34	0.41	0.48	0.677
0.18	0.25	670	52.8	58.0	58.7	0.48	0.59	0.69	0.675	685	49.3	56.0	58.7	0.43	0.53	0.62	0.688
0.25	0.33	695	54.0	60.0	64.1	0.44	0.57	0.67	0.884	705	56.0	62.0	64.3	0.39	0.50	0.60	0.902
0.37	0.5	700	61.0	66.0	69.3	0.44	0.56	0.66	1.23	710	62.0	67.0	69.5	0.38	0.50	0.59	1.26
0.55	0.75	695	65.0	70.0	73.0	0.49	0.62	0.70	1.64	705	65.0	70.0	73.0	0.42	0.55	0.64	1.64
0.75	1	705	73.9	76.1	75.1	0.44	0.57	0.66	2.30	715	71.1	74.8	75.5	0.38	0.50	0.59	2.34
1.1	1.5	700	74.9	76.8	77.7	0.45	0.58	0.66	3.26	710	71.1	76.0	77.7	0.38	0.50	0.59	3.34
1.5	2	700	79.0	79.5	79.7	0.49	0.63	0.71	4.03	710	77.9	79.7	79.9	0.42	0.56	0.65	4.02
2.2	3	705	81.5	81.9	81.9	0.57	0.68	0.76	5.37	715	81.0	82.0	82.2	0.48	0.62	0.70	5.32
3	4	705	83.4	83.5	83.5	0.56	0.68	0.75	7.28	715	81.5	83.2	83.7	0.48	0.61	0.70	7.12
4	5.5	720	85.6	86.8	86.1	0.56	0.68	0.74	9.54	730	84.4	86.6	86.8	0.49	0.62	0.70	9.16
5.5	7.5	720	86.7	87.3	87.2	0.56	0.68	0.76	12.6	730	85.2	87.0	87.8	0.49	0.62	0.71	12.3
7.5	10	725	87.8	88.5	88.6	0.56	0.69	0.76	16.9	730	86.2	88.0	88.9	0.49	0.62	0.71	16.5
9.2	12.5	720	89.2	89.1	88.9	0.67	0.78	0.84	18.7	730	88.6	89.3	90.0	0.60	0.73	0.80	17.8
11	15	720	90.0	90.0	89.8	0.59	0.71	0.77	24.2	725	89.0	89.9	90.5	0.52	0.65	0.74	22.9
15	20	730	90.5	91.0	91.0	0.60	0.71	0.76	33.0	730	89.0	89.6	89.8	0.53	0.65	0.72	31.7

17. Mechanical Data (Standard)

17.1 Motors with Top Mounted Terminal Box

Frames 63 to 132M/L

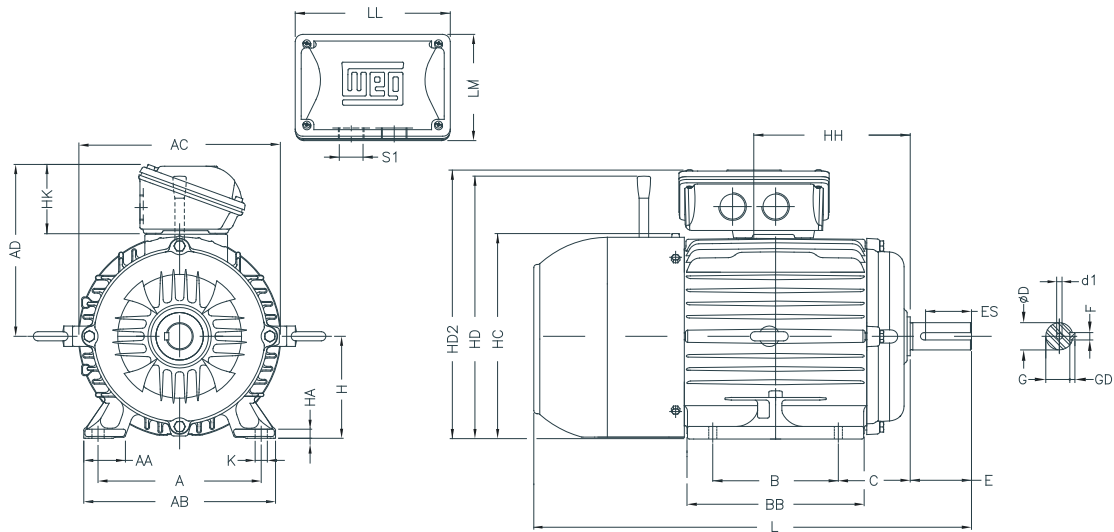

Frames 160M to 200L

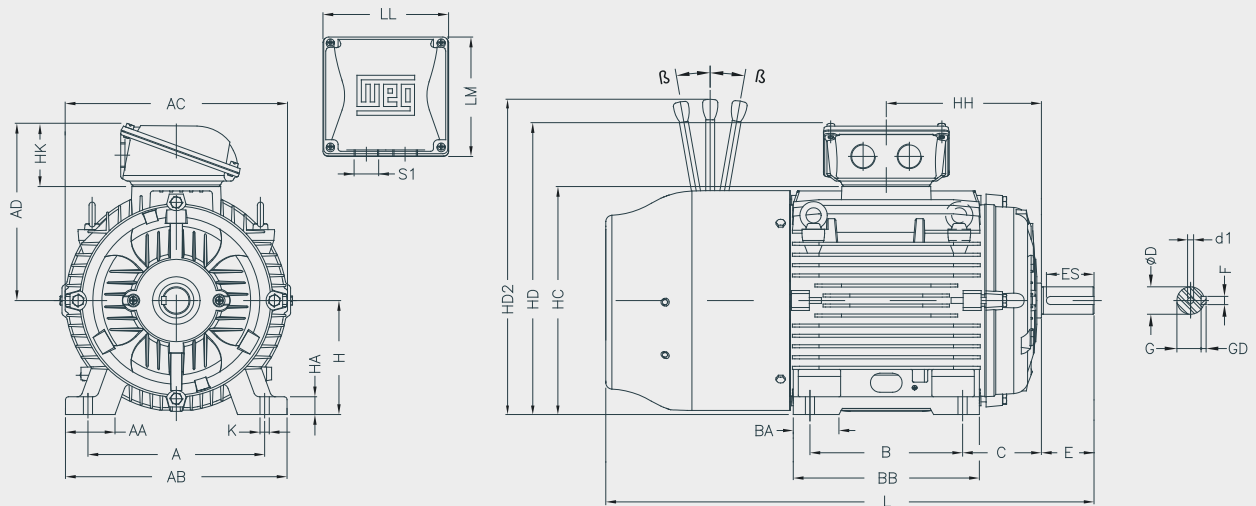

Frames 225S/M to 250S/M

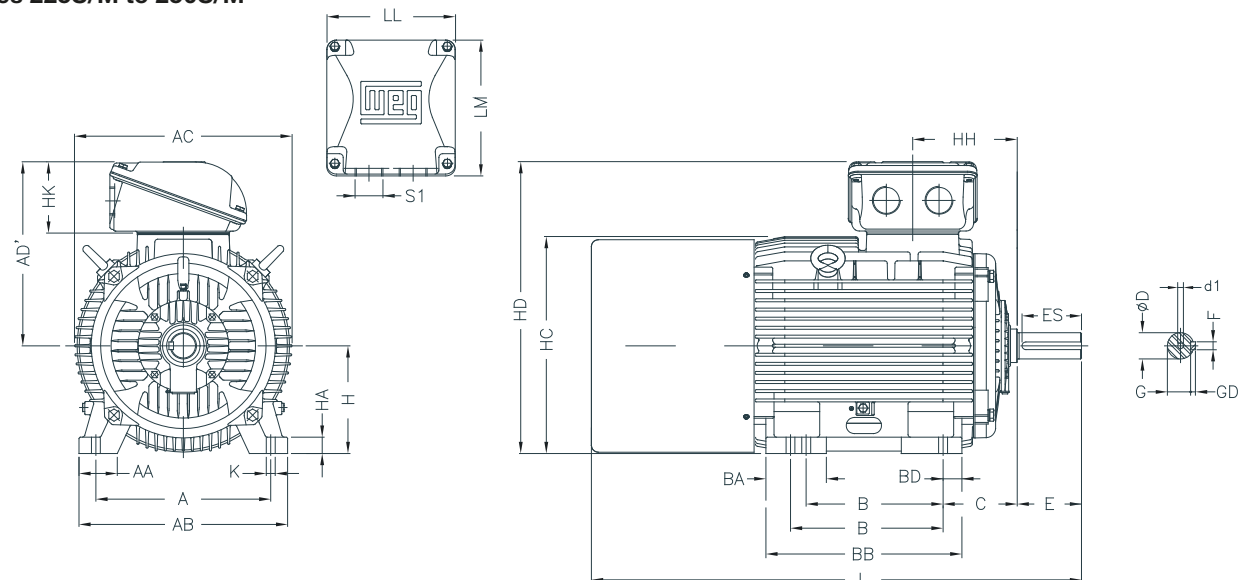

Frame	A	AA	AB	AC	AD and AD'	B	BA	BB	BD	Shaft					
										D	E	ES	F	G	GD
63	100	25.5	116	125	132	80		95		11j6	23	14	4	8,5	4
71	112	28.5	132	141	140	90		113.5		14j6	30	18	5	11	5
80	125	30.5	149	159	148	100		125.5		19j6	40	28	6	15.5	6
90S	140	36.5	164	179	157	125		131		24j6	50	36	8	20	7
90L															
100L	160	40	188	199	170	140		159		28j6	60	45		24	
112M	190	40.5	220	222	191										
132S	216	45	248	272	218			187		38k6	80	63	10	33	8
132M															
132M/L															
160M	254	64	308	329	257		210	254	63	42k6			12	37	
160L															
180M	279	78	350	360	273		241	294	70	48k6	110	80	14	42.5	9
180L															
200M	318	82	385	402	310		267	332	82	55m6			16	49	10
200L															
225S/M	356	80	436	455	408	286/311	124	412	41	60m6	140	125	18	53	11
250S/M	406	100	506	486		311/349	146	467	59	65m6				58	

Frame	C	H	HA	HC	HD	HH	HK	LL	LM	K	L	S1	d1	Bearings		Manual release			
														D.E.	N.D.E.	HD2	β		
63	40	63	7	129	195	80				7	260	2xM20x1.5	A3.15	6201-ZZ	6201-ZZ	170	12°		
71	45	71		145	211	90					300			6202-ZZ	6202-ZZ	207	10°		
80	50	80	8	163	228	100	69	150	110	10	335			6204-ZZ	6203-ZZ	215	10°		
90S	56	90	9	182	247	106					118.5			401	2xM25x1.5	6205-ZZ		6204-ZZ	222
90L																			
100L	63	100	10	205	270	133				12	460			6206-ZZ	6205-ZZ	260	10°		
112M	70	112		235	303	140					482			6207-ZZ	6206-ZZ	305	9°		
132S	89	132	16	266	350	178	77	167	138		547	2xM32x1.5	A4	6308-ZZ	6207-ZZ	370	10°		
132M																			
132M/L																			
160M	108	160	22	327	417	213				100	198.5	190	14.5	719	2xM40x1.5	6309-C3	6209-C3	438	9°
160L																			
180M	121	180	28	363	453	241.5					792			6311-C3	6211-C3	497	10°		
180L																			
200M	133	200	30	405	510	266.5	118	230	220	18.5	858			6312-C3	6212-C3	644			
200L																			
225S/M	149	225	34	453	633	212	143	269	285	24	1045	2xM50x1.5	M20	6314-C3	6314-C3	X	X		
250S/M	168	250	43	493	658	214					1124							2xM63x1.5	



17.2 Motors with Side Mounted Terminal Box

Frames 63 to 132M/L

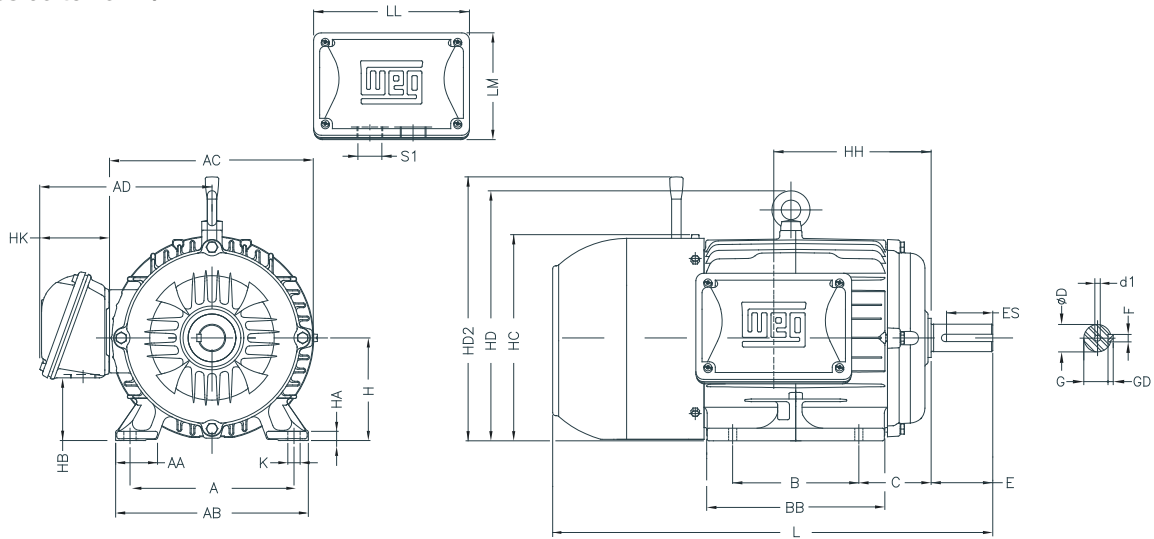

Frames 160M to 200L

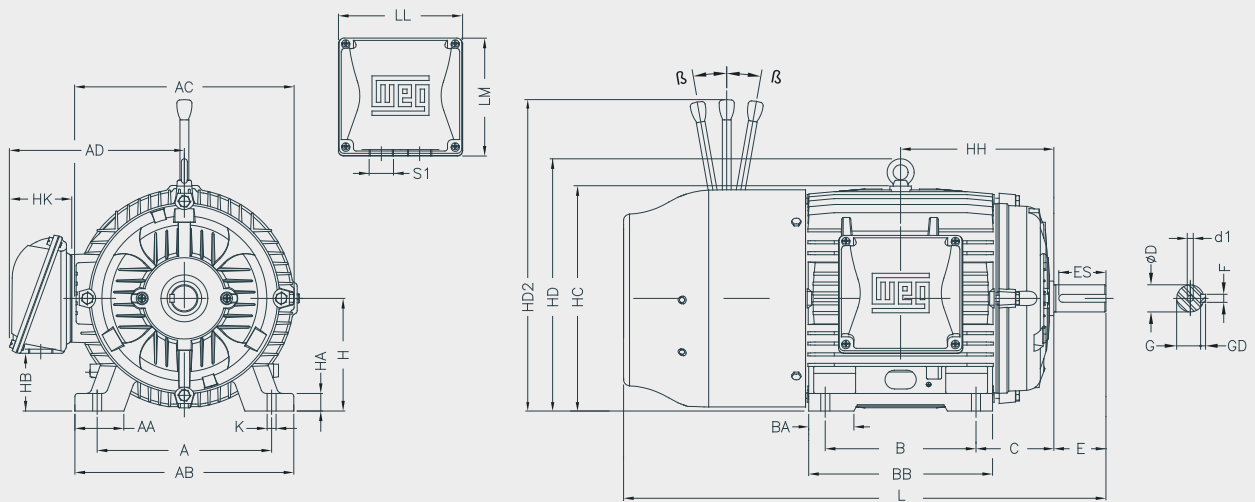

Frames 225S/M to 250S/M

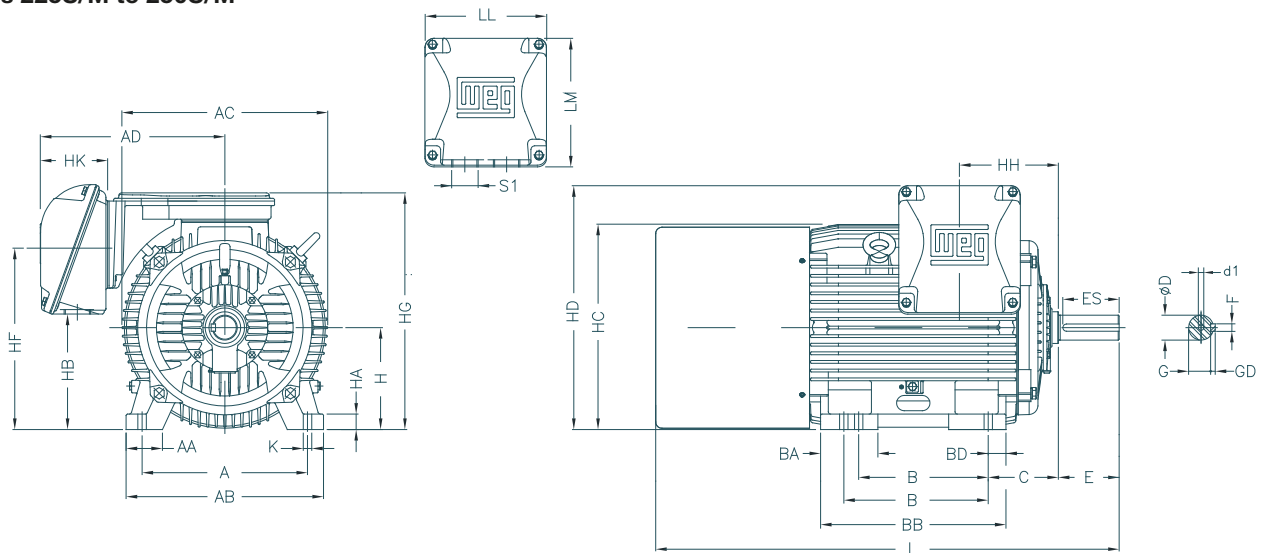

Frame	A	AA	AB	AC	AD	B	BA	BB	C	Shaft						
										D	E	ES	F	G	GD	
63	100	25.5	116	125	132	80	-	95	40	11j6	23	14	4	8,5	4	
71	112	28.5	132	141	140	90	-	113.5	45	14j6	30	18	5	11	5	
80	125	30.5	149	159	148	100	-	125.5	50	19j6	40	28	6	15.5	6	
90S	140	36.5	164	179	157	125	-	131	56	24j6	50	36	8	20	7	
90L								159								
100L	160	40	188	199	170	140	-	173	63	28j6	60	45	8	24	7	
112M	190	40.5	220	222	191			177								70
132S	216	45	248	272	218	178	-	187	89	38k6	80	63	10	33	8	
132M								210								225
132M/L								178/203								250
160M	254	64	308	329	257	210	63	254	108	42k6	110	80	12	37	9	
160L								298								
180M	279	78	350	360	273	241	70	294	121	48k6	110	80	14	42.5	9	
180L								279								332
200M	318	82	385	402	310	267	82	370	133	55m6	110	80	16	49	10	
200L								305								370
225S/M	356	80	436	455	408	286/311	124	412	149	60m6	140	125	18	53	11	
250S/M	406	100	506	486		311/349	146	467	168	65m6				58		

Frame	H	HA	HB	HC	HD	HF	HG	HH	HK	LL	LM	K	L	S1	d1	Bearings		Manual release	
																D.E.	N.D.E.	HD2	β
63	63	7	23.5	129	-	67.5	-	80	69	150	110	7	260	2xM20x1.5	A3.15	6201-ZZ	6201-ZZ	170	12°
71	71		31	145		76		90								300	6202-ZZ	6202-ZZ	207
80	80	8	41.5	163	85.5	100	-	106	77	167	138	10	376	2xM25x1.5	A4	6204-ZZ	6203-ZZ	215	10°
90S	90	9	45	182	105	118.5		118.5								401	10	460	6205-ZZ
90L						100L	100	10	61.5	205	244	133	12	482	6206-ZZ	6205-ZZ	260	10°	
112M	112	16	54	235	280	112	-	140	100	198.5	190	14.5	719	2xM32x1.5	A4	6207-ZZ	6206-ZZ	305	9°
132S	132		74	266	319	131.5		159								178	547	12	547
132M		132M/L	16	74	266	319	131.5	-	190.5	100	198.5	190	14.5	604.5	2xM40x1.5	A4	6309-C3	6209-C3	438
160M	213								213										
160L	160	22	79	327	374	168	-	235	100	198.5	190	14.5	763	2xM50x1.5	M20	6311-C3	6211-C3	497	10°
180M	180	28	92	363	413	180		241.5								260.5	18.5	858	6312-C3
180L							266.5	285.5	919	919	18.5	919	6312-C3	6212-C3	644	10°			
200M	200	30	119	405	464	218	-	266.5	118	230	220	18.5	858	2xM50x1.5	M20	6314-C3	6314-C3	X	X
200L								285.5											
225S/M	225	34	255	453	541	403	534	212	143	269	285	24	1045	2xM63x1.5	M20	6314-C3	6314-C3	X	X
250S/M	250	43	290	493	583	449	577	214	143	269	285	24	1124	2xM63x1.5	M20	6314-C3	6314-C3	X	X



WEG Worldwide Operations

ARGENTINA

WEG EQUIPAMIENTOS
ELECTRICOS
San Francisco - Cordoba
Phone: +54 3564 421 484
info-ar@weg.net
www.weg.net/ar

WEG PINTURAS - Pulverlux
Buenos Aires
Phone: +54 11 4299 8000
tintas@weg.net

AUSTRALIA

WEG AUSTRALIA
Victoria
Phone: +61 3 9765 4600
info-au@weg.net
www.weg.net/au

AUSTRIA

WATT DRIVE - WEG Group
Markt Piesting
Phone: +43 2633 404 0
watt@wattdrive.com
www.wattdrive.com

BELGIUM

WEG BENELUX
Nivelles - Belgium
Phone: +32 67 88 84 20
info-be@weg.net
www.weg.net/be

BRAZIL

WEG EQUIPAMENTOS ELÉTRICOS
Jaraguá do Sul - Santa Catarina
Phone: +55 47 3276-4002
info-br@weg.net
www.weg.net/br

CHILE

WEG CHILE
Santiago
Phone: +56 2 784 8900
info-cl@weg.net
www.weg.net/cl

CHINA

WEG NANTONG
Nantong - Jiangsu
Phone: +86 0513 8598 9333
info-cn@weg.net
www.weg.net/cn

COLOMBIA

WEG COLOMBIA
Bogotá
Phone: +57 1 416 0166
info-co@weg.net
www.weg.net/co

ECUADOR

WEG ECUADOR
Quito
Phone: 5144 339/342/317
wegecuador@weg.net
www.weg.net/ec

FRANCE

WEG FRANCE
Saint Quentin Fallavier - Lyon
Phone: +33 4 74 99 11 35
info-fr@weg.net
www.weg.net/fr

GERMANY

WEG GERMANY
Kerpen
Phone: +49 2237 9291 0
info-de@weg.net
www.weg.net/de

WEG BALINGEN

Balingen
Phone: +49 7433 9041 0
info@weg-antriebe.de
www.weg-antriebe.de

GHANA

ZEST ELECTRIC GHANA -
WEG Group
Accra
Phone: +233 30 27 664 90
info@zestghana.com.gh
www.zestghana.com.gh

INDIA

WEG ELECTRIC INDIA
Bangalore - Karnataka
Phone: +91 80 4128 2007
info-in@weg.net
www.weg.net/in

WEG INDUSTRIES INDIA

Hosur - Tamil Nadu
Phone: +91 4344 301 577
info-in@weg.net
www.weg.net/in

ITALY

WEG ITALIA
Cinisello Balsamo - Milano
Phone: +39 02 6129 3535
info-it@weg.net
www.weg.net/it

JAPAN

WEG ELECTRIC MOTORS
JAPAN
Yokohama City - Kanagawa
Phone: +81 45 550 3030
info-jp@weg.net
www.weg.net/jp

MALAYSIA

WATT EURO-DRIVE - WEG Group
Shah Alam - Selangor
Phone: 603 78591626
info@wattdrive.com.my
www.wattdrive.com

MEXICO

WEG MEXICO
Huehuetoca
Phone: +52 55 5321 4231
info-mx@weg.net
www.weg.net/mx

VOLTRAN - WEG Group

Tizayuca - Hidalgo
Phone: +52 77 5350 9354
www.voltran.com.mx

NETHERLANDS

WEG NETHERLANDS -
Oldenzaal - Overijssel
Phone: +31 541 571 080
info-nl@weg.net
www.weg.net/nl

PERU

WEG PERU
Lima
Phone: +51 1 209 7600
info-pe@weg.net
www.weg.net/pe

PORTUGAL

WEG EURO
Maia - Porto
Phone: +351 22 9477705
info-pt@weg.net
www.weg.net/pt

RUSSIA and CIS

WEG ELECTRIC CIS
Saint Petersburg
Phone: +7 812 363 2172
info-ru@weg.net
www.weg.net/ru

SOUTH AFRICA

ZEST ELECTRIC MOTORS
WEG Group
Johannesburg
Phone: +27 11 723 6000
info@zest.co.za
www.zest.co.za

SPAIN

WEG IBERIA
Madrid
Phone: +34 91 655 30 08
info-es@weg.net
www.weg.net/es

SINGAPORE

WATT EURO-DRIVE - WEG Group
Singapore
Phone: +65 6 862 2220
watteuro@watteuro.com.sg
www.wattdrive.com

WEG SINGAPORE

Singapore
Phone: +65 68589081
info-sg@weg.net
www.weg.net/sg

SCANDINAVIA

WEG SCANDINAVIA
Mölnlycke - Sweden
Phone: +46 31 888000
info-se@weg.net
www.weg.net/se

UK

WEG ELECTRIC MOTORS U.K.
Redditch - Worcestershire
Phone: +44 1527 513 800
info-uk@weg.net
www.weg.net/uk

UNITED ARAB EMIRATES

WEG MIDDLE EAST
Dubai
Phone: +971 4 813 0800
info-ae@weg.net
www.weg.net/ae

USA

WEG ELECTRIC
Duluth - Georgia
Phone: +1 678 249 2000
info-us@weg.net
www.weg.net/us

ELECTRIC MACHINERY -

WEG Group
Minneapolis - Minnesota
Phone: +1 612 378 8000
www.electricmachinery.com

VENEZUELA

WEG INDUSTRIAS VENEZUELA
Valencia - Carabobo
Phone: +58 241 821 0582
info-ve@weg.net
www.weg.net/ve

For those countries where there is not a WEG own operation, find our local distributor at www.weg.net.



WEG Group - Motors Business Unit
Jaraguá do Sul - SC - Brazil
Phone: +55 47 3276 4000
motores@weg.net
www.weg.net

